

**ADDENDUM NO. 1
TO THE
BIDDING DOCUMENTS
FOR
BID NUMBER #24210
WRF IMPROVEMENTS**

PW # 2022.117, 2022.118, 2022.119, 2022.120

**FOR
LAKE COUNTY DEPARTMENT OF PUBLIC WORKS**

DATE: February 6, 2024

TO ALL BIDDERS BIDDING ON THE ABOVE PROJECT:

All Bidders submitting a Bid on the above Contract shall carefully read this Addendum and give it consideration in the preparation of their Bid.

I. The following are revisions to the Specifications:

1. The following revisions shall be made to SECTION 40 05 05 – EXPOSED PIPING INSTALLATION:
 - A. Delete SECTION 40 05 05 page 5 and add revised SECTION 40 05 05 page 5 attached to this Addenda.
2. The following revisions shall be made to SECTION 46 66 56- UV DISINFECTION EQUIPMENT:
 - A. Page 46 66 56-8, paragraph 2.02.H, add the following:
 8. Each PDC shall have air conditioning unit.

II. The following are revisions to the Specifications Appendix:

1. The following revisions shall be made to the Table Contents:
 - A. Add the following:

12. IEPA Water Pollution Control Permit 2024-AB-68958	4 pages
13. Permit NRB-078031-2024 Contract A	6 pages
14. Permit NRB-070832-2024 Contract C	6 pages
2. Insert forms attached to this Addendum immediately after the last page of the Lake County Construction and Demolition Debris Recycling Compliance Report.

III. The following are revisions to the Drawings which pertain to Contract C:

1. Sheet 79, Drawing 035-M-3, delete Drawing 035-M-3 and add a revised Drawing 035-M-3 attached to this Addenda.

- IV. The following are revisions to the Drawings which pertain to Contract D:
1. Sheet 115, Drawing 065-M-4, delete Drawing 065-M-4 and add a revised Drawing 065-M-4 attached to this Addenda.
- V. Any revisions to any of the Contract Documents made by this Addendum shall be considered as the same revision to any and all related areas of the Contract Documents not specifically called out in this Addendum.
- VI. The Bidder shall acknowledge receipt of this Addendum by inserting the date and number in the spaces provided in the BID FORM.

DONOHUE & ASSOCIATES, INC.
SHEBOYGAN, WISCONSIN

Nathan Cassity, PE

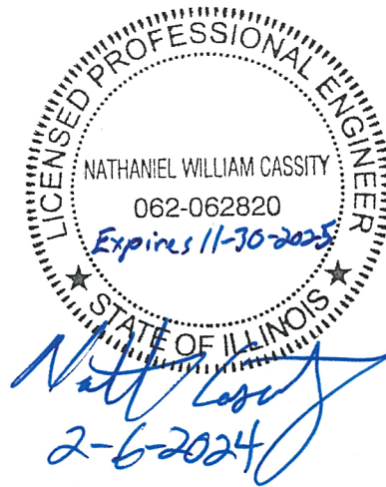

4. Test pressure for hydrostatic and high pressure air testing shall be 1.5 times maximum operating pressure, minimum, unless specified otherwise in REMARKS column. Test pressure for low pressure air testing shall be as specified in Section 40 05 10.

G. **COLOR** column: Specifies color coding and banding to be provided for non-buried piping systems. Provide color coding, banding, and labeling in accordance with Section 40 05 97. For piping scheduled to be color-coded, but not scheduled for complete painting (such as plastic piping, stainless steel piping, or aluminum insulation jacketing) provide pipe marking tape banding to represent piping color-code. At each banding location provide following sequence:

1. 8-inch wide tape of scheduled pipe color.
2. 4-inch wide tape of scheduled band color (if pipe color-code calls for banding).
3. 8-inch wide tape of scheduled pipe color (if pipe color-code calls for banding).

H. **REMARKS** column: Provides further description of piping system and specifies additional requirements.

PROCESS-MECHANICAL PIPING SCHEDULE							
Service	Size (in.)	Pipe Matl	Location	Min/Max Temp (°F)	Max Press (psig)	Color	Remarks
050 – BATTERY B FILTER BUILDING							
BWW	6	304L SS	Inside Exposed	20/100	10-H	Black	Disc Filter backwash discharge
D	6	304L SS	Inside Exposed, Submerged	20/100	10-H	Black	Disc Filter drain
D	4	PVC	Embedded, Submerged	20/100	10-H	Black	Sch 80, Filter cell drain
FEF	36	304L SS	Inside Exposed	20/100	10-H	Gray	Disc Filter effluent
SE	36	304L SS	Inside Exposed	20/100	10-H	Gray	Disc Filter influent
035 – BATTERY B BLOWER BUILDING							
ALP	16, 20, 30	304SS	Inside Exposed, Outside Exposed	-20/110	15-P	None	
065 – UV DISINFECTION BUILDING							
D	8	PVC	Buried	40/95	3	None	
D	8	CLDI	Embedded	40/95	3	None	
YARD PIPING – SEE SECTION 33 05 05							

END OF SECTION

ILLINOIS ENVIRONMENTAL PROTECTION AGENCY
WATER POLLUTION CONTROL PERMIT

LOG NUMBERS: 2023-68958
BOW ID: W0971450003

PERMIT NO.: 2024-AB-68958

FINAL PLANS, SPECIFICATIONS, APPLICATION
AND SUPPORTING DOCUMENTS

DATE ISSUED: JAN 25 2024

PREPARED BY: Donohue & Associates, Inc.

SUBJECT: LAKE COUNTY DPW – Des Plaines River WRF Improvements

RECEIVED

PERMITTEE TO CONSTRUCT AND OWN

JAN 29 2024

Lake County DPW
650 W. Winchester Road
Libertyville, Illinois 60048

Lake County Public Works

Permit is hereby granted to the above designated permittee(s) to construct and/or operate water pollution control facilities described as follows:

Replace sand filter cells 6 and 12 with two new disc filter units. After completion there will be a total of four disc filter units, each with thirty-five 2.4 meter diameter discs, 1620 ft² of submerged filter area, and 10 µm pore size rated at 11.6 MGD, 46.4 MGD total. The remaining sand filter units will remain in service to provide additional filtration capacity.

Existing blowers nos. 4 and 5 will be replaced with two new high-speed turbo blowers each rated at 6000 scfm to supply air to the aeration tanks.

Replace the existing chlorination and dechlorination systems with ultra-violet (UV) disinfection consisting of two channels with three banks per channel, low pressure high output UV lamps with 90% UV emission at 253.7 nanometer wave length and mechanical wipers. The new UV system will be located upstream of the existing post-aeration system in a new structure. The UV system inlet and outlet will tie into the existing 72-inch filter effluent piping using diversion structures and isolation gates.

Install launder covers for final clarifiers no. 1, 2, 3, 4, 5, and 6 to inhibit the growth of algae on launder troughs and weirs of clarifier by minimizing incident sunlight on surfaces. The launder covers consist of a system of molded fiberglass panels that are attached together to form a continuous cover over the launder trough, weir and scum baffle within the treatment tank.

The rated capacities of the above referenced treatment plant will not change as a result of these improvements.

Unless the construction for which this permit is issued has been completed, this permit will expire three years after the date of issuance.

This Permit is issued subject to the following Special Condition(s). If such Special Condition(s) require(s) additional or revised facilities, satisfactory engineering plan documents must be submitted to this Agency for review and approval for issuance of a Supplemental Permit.

SPECIAL CONDITION 1: The operational portion of this permit shall be governed by NPDES Permit No. IL0022055.

SPECIAL CONDITION 2: The Permittee to Construct shall be responsible for obtaining an NPDES Storm Water Permit prior to initiating construction if the construction activities associated with this project will result in the disturbance of one

Page 1 of 2

THE STANDARD CONDITIONS OF ISSUANCE INDICATED ON THE REVERSE SIDE MUST BE COMPLIED WITH IN FULL. READ ALL CONDITIONS CAREFULLY.

BDF:JAR:2023-68958

DIVISION OF WATER POLLUTION CONTROL

cc: EPA-Des Plaines FOS
Records - Municipal
Donohue & Associates, Inc.

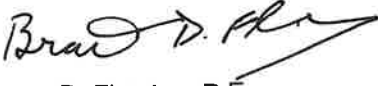
Brant D. Fleming, P.E.
Manager, Municipal Unit, Permit Section

ILLINOIS ENVIRONMENTAL PROTECTION AGENCY
WATER POLLUTION CONTROL PERMIT

LOG NUMBERS: 2023-68958
BOW ID: W0971450003

PERMIT NO.: 2024-AB-68958

FINAL PLANS, SPECIFICATIONS, APPLICATION
AND SUPPORTING DOCUMENTS
PREPARED BY: Donohue & Associates, Inc.

DATE ISSUED: JAN 25 2024

SUBJECT: LAKE COUNTY DPW – Des Plaines River WRF Improvements

(1) or more acres total land area. Additional information is provided on the following webpage:
<https://epa.illinois.gov/topics/forms/water-permits/storm-water/construction.html>

SPECIAL CONDITION 3: This permit also covers all necessary appurtenances not specifically mentioned herein but detailed in the specifications and/or the design drawings.

SPECIAL CONDITION 4: The issuance of this permit does not release the permittee to construct from any obligation to comply with the requirements of the Illinois State Agency Historic Resources Preservation Act or the Illinois Historic Preservation Office.

SPECIAL CONDITION 5: The issuance of this permit is not to be construed as an approval of the "Water Pollution Control Revolving Fund" loan program requirements.

**READ ALL CONDITIONS CAREFULLY:
STANDARD CONDITIONS**

The Illinois Environmental Protection Act (Illinois Revised Statutes Chapter 111-12, Section 1039) grants the Environmental Protection Agency authority to impose conditions on permits which it issues.

1. Unless the construction for which this permit is issued has been completed, this permit will expire (1) two years after the date of issuance for permits to construct sewers or wastewater sources or (2) three years after the date of issuance for permits to construct treatment works or pretreatment works.
2. The construction or development of facilities covered by this permit shall be done in compliance with applicable provisions of Federal laws and regulations, the Illinois Environmental Protection Act, and Rules and Regulations adopted by the Illinois Pollution Control Board.
3. There shall be no deviations from the approved plans and specifications unless a written request for modification of the project, along with plans and specifications as required, shall have been submitted to the Agency and a supplemental written permit issued.
4. The permittee shall allow any agent duly authorized by the Agency upon the presentations of credentials:
 - a. to enter at reasonable times, the permittee's premises where actual or potential effluent emission or noise source are located or where any activity is to be conducted pursuant to this permit;
 - b. to have access to and copy at reasonable times any records required to be kept under the terms and conditions of this permit;
 - c. to inspect at reasonable times, including during any hours of operation of equipment constructed or operated under this permit, such equipment or monitoring methodology or equipment required to be kept, used, operated, calibrated and maintained under this permit;
 - d. to obtain and remove at reasonable times samples of any discharge or emission of pollutants;
 - e. to obtain and remove at reasonable times and utilize any photographic, recording, testing, monitoring or other equipment for the purpose of preserving, testing monitoring, or recording any activity, discharge, or emission authorized by this permit.
5. The issuance of this permit:
 - a. shall not be considered as in any manner affecting the title of the premises upon which the permitted facilities are to be located;
 - b. does not release the permittee from any liability for damages to person or property caused by or resulting from construction, maintenance, or operation of the proposed facilities;
 - c. does not release the permittee from compliance with other applicable statutes and regulations of the United States, of the State of Illinois, or other applicable local laws, ordinances and regulations;
 - d. does not take into consideration or attest to structural stability of any units or parts of the project;
 - e. in no manner implies or suggests that the Agency (or its officers, agents or employees) assumes any liability, directly or indirectly, for any loss due to damage, installation, maintenance, or operation of the proposed equipment or facility.
6. Unless a joint construction/operation permit has been issued, a permit for operating shall be obtained from the agency before the facility or equipment covered by this permit is placed into operation.
7. These standard conditions shall prevail unless modified by special conditions.
8. The Agency may file a complaint with the Board for suspension or revocation of a permit:
 - a. upon discovery that the permit application contained misrepresentations, misinformation or false statement or that all relevant facts were not disclosed; or
 - b. upon finding that any standard or special conditions have been violated; or
 - c. upon any violation of the Environmental Protection Act or Any Rules or Regulation effective thereunder as a result of the construction or development authorized by this permit.

**READ ALL CONDITIONS CAREFULLY:
STANDARD CONDITIONS**

The Illinois Environmental Protection Act (Illinois Revised Statutes Chapter 111-12, Section 1039) grants the Environmental Protection Agency authority to impose conditions on permits which it issues.

1. Unless the construction for which this permit is issued has been completed, this permit will expire (1) two years after the date of issuance for permits to construct sewers or wastewater sources or (2) three years after the date of issuance for permits to construct treatment works or pretreatment works.
2. The construction or development of facilities covered by this permit shall be done in compliance with applicable provisions of Federal laws and regulations, the Illinois Environmental Protection Act, and Rules and Regulations adopted by the Illinois Pollution Control Board.
3. There shall be no deviations from the approved plans and specifications unless a written request for modification of the project, along with plans and specifications as required, shall have been submitted to the Agency and a supplemental written permit issued.
4. The permittee shall allow any agent duly authorized by the Agency upon the presentations of credentials:
 - a. to enter at reasonable times, the permittee's premises where actual or potential effluent emission or noise source are located or where any activity is to be conducted pursuant to this permit;
 - b. to have access to and copy at reasonable times any records required to be kept under the terms and conditions of this permit;
 - c. to inspect at reasonable times, including during any hours of operation of equipment constructed or operated under this permit, such equipment or monitoring methodology or equipment required to be kept, used, operated, calibrated and maintained under this permit;
 - d. to obtain and remove at reasonable times samples of any discharge or emission of pollutants;
 - e. to obtain and remove at reasonable times and utilize any photographic, recording, testing, monitoring or other equipment for the purpose of preserving, testing monitoring, or recording any activity, discharge, or emission authorized by this permit.
5. The issuance of this permit:
 - a. shall not be considered as in any manner affecting the title of the premises upon which the permitted facilities are to be located;
 - b. does not release the permittee from any liability for damages to person or property caused by or resulting from construction, maintenance, or operation of the proposed facilities;
 - c. does not release the permittee from compliance with other applicable statutes and regulations of the United States, of the State of Illinois, or other applicable local laws, ordinances and regulations;
 - d. does not take into consideration or attest to structural stability of any units or parts of the project;
 - e. in no manner implies or suggests that the Agency (or its officers, agents or employees) assumes any liability, directly or indirectly, for any loss due to damage, installation, maintenance, or operation of the proposed equipment or facility.
6. Unless a joint construction/operation permit has been issued, a permit for operating shall be obtained from the agency before the facility or equipment covered by this permit is placed into operation.
7. These standard conditions shall prevail unless modified by special conditions.
8. The Agency may file a complaint with the Board for suspension or revocation of a permit:
 - a. upon discovery that the permit application contained misrepresentations, misinformation or false statement or that all relevant facts were not disclosed; or
 - b. upon finding that any standard or special conditions have been violated; or
 - c. upon any violation of the Environmental Protection Act or Any Rules or Regulation effective thereunder as a result of the construction or development authorized by this permit.

STAPLE/FASTEN IN THIS BOX



Lake County Central Permit Facility
500 West Winchester Road
Libertyville, Illinois 60048-1331
Phone: 847.377.2600
E-mail: lcpermits@lakecountyil.gov

LAKE COUNTY, IL

PERMIT

HAS BEEN SECURED FOR PROJECT #
NRB-078031-2024

Project Description: Alterations

Property Address: 800 KRAUSE DR BUFFALO GROVE

PIN: 1534200580

Date Issued: 2/6/2024

Project Permits

Permit # _____

Issued: _____

Project Issued By: _____

Frank Olson, Project Manager

A FAILURE TO CALL FOR THE INSPECTIONS OR MEET THE CONDITIONS LISTED ON THIS PERMIT CARD MAY RESULT IN A VIOLATION. IF THERE ARE ANY QUESTIONS REGARDING THIS PROJECT, THE PROJECT'S ASSOCIATED INSPECTIONS OR CONDITIONS PLEASE CALL THE PROJECT MANAGER LISTED ABOVE AT 847-377-2600.

NOT ALL BUILDING INSPECTIONS ARE REQUIRED. PLEASE CALL 847-377-2600 FOR QUESTIONS ON REQUIRED INSPECTIONS AND TO SCHEDULE INSPECTIONS.

1. FOOTING/ SETBACK	2. DRAIN TILE	3. DAMPPROOF FOUNDATION	4. ROUGH CARPENTRY	5. ROUGH MASONRY	6. ROUGH ELECTRICAL	7. ROUGH ELECTRICAL IN CONC SLAB	8. ROUGH PLUMBING
9. ROUGH PLUMBING IN CONC SLAB	10. ROUGH HVAC	11. INSULATION	12. WATER SUPPLY	13. SWIMMING POOLS	14. OCCUPANCY & USE CERTIFICATE	15. ELEVATOR	16. FINAL INSPECTION

SEE THE BACKSIDE OF THIS CARD FOR ALL PROJECT CONDITIONS.

POST THIS CARD AT THE PROJECT SITE ENSURING IT IS VISIBLE FROM THE STREET AND SUCH THAT THE INSPECTOR CAN RECORD THE OUTCOME OF THE INSPECTIONS ON THIS CARD. DO NOT POST THIS CARD IN THE INTERIOR OF A BUILDING. INSPECTORS AND SHERIFF'S DEPUTIES ARE INSTRUCTED TO STOP ALL WORK WHERE THIS PERMIT CARD IS NOT DISPLAYED.

PERMIT CONDITIONS / NOTICE TO APPLICANT



NOTICE TO APPLICANT

BUILDINGS

All new building, structures and signs shall conform to all applicable requirements of the Unified Development Ordinance (UDO) and the Building Code.

CHANGE OF OCCUPANCY

The use or purpose for which a building is to be used shall not be changed until a Change of use Permit and a Certificate of Occupancy permitting the new use or occupancy is issued by the Building Official.

VIOLATIONS AND PENALTIES

Every permit issued by the Building Official, under the provision of the Building Code shall expire by limitation and become null and void if the authorized work is not commenced within 6 months unless renewed. Before work can again be resumed, a new permit will be required. Any person, firm or corporation violating the provisions of this Ordinance is subject to the fines and penalties as provided by the law.

INSPECTION PROCEDURE

Inspection requests require a 24-hour notice except for footing/pre-pour inspections. Footing/pre-pour inspections require a 4-hour notice. Inspection time frames are AM (8-12) or PM (12-4), Monday through Friday & must be received no later than 12PM for the following AM timeframe and no later than 3PM for the following PM timeframe.

Fill out the inspection request form at: www.lakecountyiil.gov/OnlineInspectionRequest or by calling the main office number at 847-377-2600

1. Footing and Setback*
2. Pre-pour (foundation walls, interior slabs, etc.)
3. Drain Tile and Damp Proof
4. Rough Carpentry (framing)
5. Electrical (rough, underground, above-ceiling, etc.)
6. Plumbing (rough, underground, above-ceiling, etc.)
7. HVAC (rough, underground, above-ceiling, etc.)
8. Rough Masonry
9. Insulation
10. Final** (occupancy, temp-use certificate, etc.)

**Iron pipes must be readily visible and accessible with witness stakes in place at the time of footing and setback inspections. If circumstances warrant, a complete and current survey of the property in questions can and may be required by the Building Official.*

***Final Inspections may have additional steps that may be required prior to scheduling. Please check the final inspections section to confirm all requirements have been met.*

NOTE: ADDITIONAL INSPECTIONS MAY BE REQUIRED

INSPECTION PROCEDURE (CONTINUED)

COMMERCIAL INSPECTIONS

Commercial pre-inspections & finals must be called into the office at 847-377-2600. These inspections have a set time scheduled. All other inspections can be scheduled as detailed above.

FINAL INSPECTIONS

Before calling for a Certificate of Occupancy/Final Inspection for your project please ensure that the following steps are completed at least 10 days prior:

1. Projects over 1,500 square feet must complete and submit a Construction & Demolition Debris Report (C&D Report) along with receipts/reports obtained from hauling company.
2. New House Projects – Blower Door/Duct Tightness Test Certificate must be submitted.
3. Septic and/or Well Approval – If your project involves a repair, replacement, or installation of the septic or water well please call 847-377-8020 to schedule a final.
4. Site Development (Engineering) – If a Site Development permit was issued for your project please submit request at www.lakecountyil.gov/OnlineInspectionRequest or call 847-377-2600 to schedule a Site Final.

Once these requirements have been met, if there are no other outstanding issues a Building Permit final may be scheduled.



Lake County Fire Chiefs Association
Northern Illinois Fire Inspectors Association

To: Applicant for Lake County Building Permit

From: Lake County Fire Chiefs Association
Northern Illinois Fire Inspectors Association

Subject: Fire Protection District Fire Prevention Codes

The Lake County Fire Chiefs Association and the Northern Illinois Fire Inspectors Association want to take this opportunity to remind all building permit applicants to check with their local fire protection district for additional fire prevention code requirements. There may be other fire prevention code requirements you need to be aware of as you start your building project. For example, a number of fire protection districts have joined local Municipalities in adopting fire prevention codes requiring residential sprinkler systems for new single family homes.

Your local fire protection district has the legal authority to adopt and enforce its own ordinance. The Illinois Supreme Court has authorized fire protection districts to enforce their fire prevention codes in the unincorporated areas of Lake County even though the code may not be required by the Lake County Building Code.

For assistance in determining the fire protection district for your building project, visit the Lake County Web Site <http://www.co.lake.il.us> → GIS Maps → Interactive GIS Map Application → Property Tax → Report Information.

Lake County fire department contact information is available by visiting the Lake County Fire Chiefs Association Web Site <http://www.lakecountyfirechiefs.org> → Members.

Please join your local fire protection district in their effort to provide life safety protection for you and your family as well as your property.

Thank you for your cooperation.

Lake County Fire Chiefs Association
Northern Illinois Fire Inspectors Association

LAKE COUNTY DEPARTMENT OF PUBLIC WORKS

WRF IMPROVEMENTS

NOTICE: REVIEW AND/OR APPROVAL OF THESE PLANS IS NOT TO IMPLY THAT ALL ERRORS AND OMISSIONS ARE NOTED HEREIN; NOR DOES IT RELIEVE THE APPLICANT FROM ADHERING TO, AND COMPLYING WITH ALL REGULATIONS OF THE BUILDING CODES AND AMENDMENTS ADOPTED BY LAKE COUNTY, AND THE LAKE COUNTY UNIFIED DEVELOPMENT ORDINANCE

THIS APPROVED SET OF PLANS MUST BE KEPT ON THE JOB SITE AT ALL TIMES FOR USE FOR USE BY THE BUILDING OFFICIAL OR HIS AUTHORIZED REPRESENTATIVE PER SECTION 107.3.1 OF THE 2018 INTERNATIONAL BUILDING CODE

CONTRACT INDEX			
ALL CONTRACTS		SHEETS 1-15	
CONTRACT A	FILTER IMPROVEMENTS	SHEETS 16-42	PW# 2022.119
CONTRACT B	CLARIFIER IMPROVEMENTS	SHEETS 43-62	PW# 2022.120
CONTRACT C	BLOWER REPLACEMENTS	SHEETS 63-80	PW# 2022.117
CONTRACT D	UV UPGRADE	SHEETS 81-121	PW# 2022.118
ALL CONTRACTS	GENERAL NOTES, SCHEDULES AND STANDARD DETAILS	SHEETS 122-138	

ALL ELECTRICAL WORK MUST COMPLY WITH ALL REQUIREMENTS OF THE 2017 NATIONAL ELECTRICAL CODE

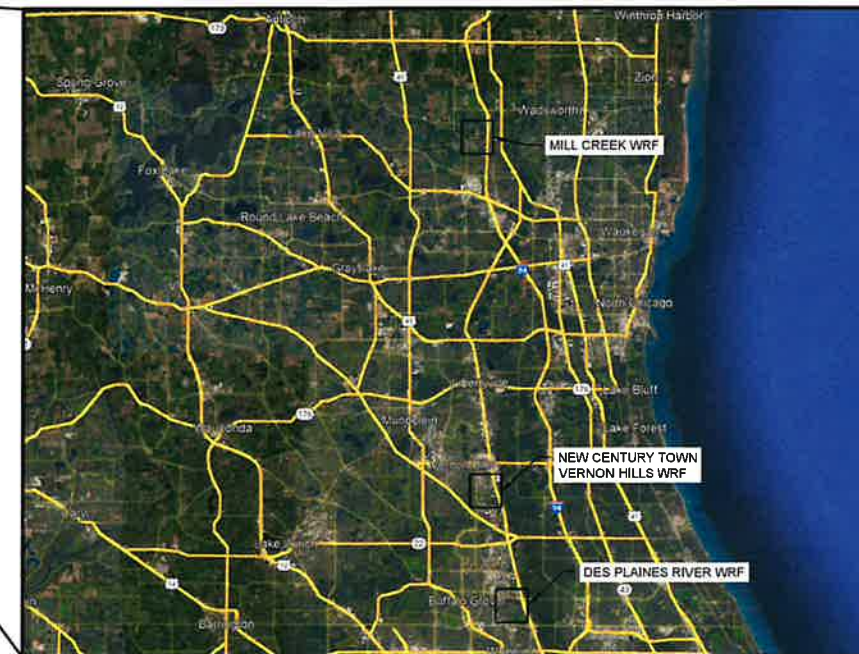

APPROVED

Subject to compliance with the I.C.C. Building and Mechanical Code, Illinois State Plumbing Code, and National Electrical Code.

PERMIT NO. NRB-078031-2024

DATE 2-6-2024

Lake County
Building Division

By ET

ILLINOIS

PROJECT LOCATIONS

LAKE COUNTY WATER RECLAMATION FACILITY INDEX		
NAME	ADDRESS	ABBREVIATION
DES PLAINES RIVER WATER RECLAMATION FACILITY	800 KRAUSE DR. BUFFALO GROVE, IL 60089	DPR
MILL CREEK WATER RECLAMATION FACILITY	16750 WEST ANCONA AVE. OLD MILL CREEK, IL 60083	MC
NEW CENTURY TOWN WATER RECLAMATION FACILITY	50 SOUTH AMERICAN WAY VERNON HILLS, IL 60061	NCT

SECURE A CERTIFICATE OF COMPLETION BEFORE OCCUPYING OR USING THIS STRUCTURE

PREPARED FOR



650 WEST WINCHESTER ROAD
LIBERTYVILLE, IL 60048
847-377-7500

PREPARED BY



3311 WEEDEN CREEK ROAD
SHEBOYGAN, WISCONSIN 53081
920-206-0296

STAPLE/FASTEN IN THIS BOX



Lake County Central Permit Facility
500 West Winchester Road
Libertyville, Illinois 60048-1331
Phone: 847.377.2600
E-mail: lcpermits@lakecountyil.gov

LAKE COUNTY, IL

PERMIT

HAS BEEN SECURED FOR PROJECT #
NRB-078032-2024

Project Description: Alterations

Property Address: 800 KRAUSE DR BUFFALO GROVE

PIN: 1534200580

Date Issued: 2/6/2024

Project Permits

Permit # _____

Issued: _____

Project Issued By: _____

Frank Olson, Project Manager

Â FAILURE TO CALL FOR THE INSPECTIONS OR MEET THE CONDITIONS LISTED ON THIS PERMIT CARD MAY RESULT IN A VIOLATION. IF THERE ARE ANY QUESTIONS REGARDING THIS PROJECT, THE PROJECT'S ASSOCIATED INSPECTIONS OR CONDITIONS PLEASE CALL THE PROJECT MANAGER LISTED ABOVE AT 847-377-2600.

NOT ALL BUILDING INSPECTIONS ARE REQUIRED. PLEASE CALL 847-377-2600 FOR QUESTIONS ON REQUIRED INSPECTIONS AND TO SCHEDULE INSPECTIONS.

1. FOOTING/ SETBACK	2. DRAIN TILE	3. DAMPPROOF FOUNDATION	4. ROUGH CARPENTRY	5. ROUGH MASONRY	6. ROUGH ELECTRICAL	7. ROUGH ELECTRICAL IN CONC SLAB	8. ROUGH PLUMBING
9. ROUGH PLUMBING IN CONC SLAB	10. ROUGH HVAC	11. INSULATION	12. WATER SUPPLY	13. SWIMMING POOLS	14. OCCUPANCY & USE CERTIFICATE	15. ELEVATOR	16. FINAL INSPECTION

SEE THE BACKSIDE OF THIS CARD FOR ALL PROJECT CONDITIONS.

POST THIS CARD AT THE PROJECT SITE ENSURING IT IS VISIBLE FROM THE STREET AND SUCH THAT THE INSPECTOR CAN RECORD THE OUTCOME OF THE INSPECTIONS ON THIS CARD. DO NOT POST THIS CARD IN THE INTERIOR OF A BUILDING. INSPECTORS AND SHERIFF'S DEPUTIES ARE INSTRUCTED TO STOP ALL WORK WHERE THIS PERMIT CARD IS NOT DISPLAYED.

PERMIT CONDITIONS / NOTICE TO APPLICANT

NOTICE TO APPLICANT

BUILDINGS

All new building, structures and signs shall conform to all applicable requirements of the Unified Development Ordinance (UDO) and the Building Code.

CHANGE OF OCCUPANCY

The use or purpose for which a building is to be used shall not be changed until a Change of use Permit and a Certificate of Occupancy permitting the new use or occupancy is issued by the Building Official.

VIOLATIONS AND PENALTIES

Every permit issued by the Building Official, under the provision of the Building Code shall expire by limitation and become null and void if the authorized work is not commenced within 6 months unless renewed. Before work can again be resumed, a new permit will be required. Any person, firm or corporation violating the provisions of this Ordinance is subject to the fines and penalties as provided by the law.

INSPECTION PROCEDURE

Inspection requests require a 24-hour notice except for footing/pre-pour inspections. Footing/pre-pour inspections require a 4-hour notice. Inspection time frames are AM (8-12) or PM (12-4), Monday through Friday & must be received no later than 12PM for the following AM timeframe and no later than 3PM for the following PM timeframe.

Fill out the inspection request form at: www.lakecountyiil.gov/OnlineInspectionRequest or by calling the main office number at 847-377-2600

1. Footing and Setback*
2. Pre-pour (*foundation walls, interior slabs, etc.*)
3. Drain Tile and Damp Proof
4. Rough Carpentry (*framing*)
5. Electrical (*rough, underground, above-ceiling, etc.*)
6. Plumbing (*rough, underground, above-ceiling, etc.*)
7. HVAC (*rough, underground, above-ceiling, etc.*)
8. Rough Masonry
9. Insulation
10. Final** (*occupancy, temp-use certificate, etc.*)

**Iron pipes must be readily visible and accessible with witness stakes in place at the time of footing and setback inspections. If circumstances warrant, a complete and current survey of the property in questions can and may be required by the Building Official.*

***Final Inspections may have additional steps that may be required prior to scheduling. Please check the final inspections section to confirm all requirements have been met.*

NOTE: ADDITIONAL INSPECTIONS MAY BE REQUIRED

INSPECTION PROCEDURE (CONTINUED)

COMMERCIAL INSPECTIONS

Commercial pre-inspections & finals must be called into the office at 847-377-2600. These inspections have a set time scheduled. All other inspections can be scheduled as detailed above.

FINAL INSPECTIONS

Before calling for a Certificate of Occupancy/Final Inspection for your project please ensure that the following steps are completed at least 10 days prior:

1. Projects over 1,500 square feet must complete and submit a Construction & Demolition Debris Report (C&D Report) along with receipts/reports obtained from hauling company.
2. New House Projects – Blower Door/Duct Tightness Test Certificate must be submitted.
3. Septic and/or Well Approval – If your project involves a repair, replacement, or installation of the septic or water well please call 847-377-8020 to schedule a final.
4. Site Development (Engineering) – If a Site Development permit was issued for your project please submit request at www.lakecountyil.gov/OnlineInspectionRequest or call 847-377-2600 to schedule a Site Final.

Once these requirements have been met, if there are no other outstanding issues a Building Permit final may be scheduled.



Lake County Fire Chiefs Association
Northern Illinois Fire Inspectors Association

To: Applicant for Lake County Building Permit

From: Lake County Fire Chiefs Association
Northern Illinois Fire Inspectors Association

Subject: Fire Protection District Fire Prevention Codes

The Lake County Fire Chiefs Association and the Northern Illinois Fire Inspectors Association want to take this opportunity to remind all building permit applicants to check with their local fire protection district for additional fire prevention code requirements. There may be other fire prevention code requirements you need to be aware of as you start your building project. For example, a number of fire protection districts have joined local Municipalities in adopting fire prevention codes requiring residential sprinkler systems for new single family homes.

Your local fire protection district has the legal authority to adopt and enforce its own ordinance. The Illinois Supreme Court has authorized fire protection districts to enforce their fire prevention codes in the unincorporated areas of Lake County even though the code may not be required by the Lake County Building Code.

For assistance in determining the fire protection district for your building project, visit the Lake County Web Site <http://www.co.lake.il.us> → GIS Maps → Interactive GIS Map Application → Property Tax → Report Information.

Lake County fire department contact information is available by visiting the Lake County Fire Chiefs Association Web Site <http://www.lakecountyfirechiefs.org> → Members.

Please join your local fire protection district in their effort to provide life safety protection for you and your family as well as your property.

Thank you for your cooperation.

Lake County Fire Chiefs Association
Northern Illinois Fire Inspectors Association

LAKE COUNTY DEPARTMENT OF PUBLIC WORKS

WRF IMPROVEMENTS

NOTICE: REVIEW AND/OR APPROVAL OF THESE PLANS IS NOT TO IMPLY THAT ALL ERRORS AND OMISSIONS ARE NOTED HEREIN; NOR DOES IT RELIEVE THE APPLICANT FROM ADHERING TO, AND COMPLYING WITH ALL REGULATIONS OF THE BUILDING CODES AND AMENDMENTS ADOPTED BY LAKE COUNTY, AND THE LAKE COUNTY UNIFIED DEVELOPMENT ORDINANCE

CONTRACT INDEX			
ALL CONTRACTS		SHEETS 1-15	
CONTRACT A	FILTER IMPROVEMENTS	SHEETS 16-42	PW# 2022.119
CONTRACT B	CLARIFIER IMPROVEMENTS	SHEETS 43-62	PW# 2022.120
CONTRACT C	BLOWER REPLACEMENTS	SHEETS 63-80	PW# 2022.117
CONTRACT D	UV UPGRADE	SHEETS 81-121	PW# 2022.118
ALL CONTRACTS	GENERAL NOTES, SCHEDULES AND STANDARD DETAILS	SHEETS 122-138	

THIS APPROVED SET OF PLANS MUST BE KEPT ON THE JOB SITE AT ALL TIMES FOR USE FOR USE BY THE BUILDING OFFICIAL OR HIS AUTHORIZED REPRESENTATIVE PER SECTION 107.3.1 OF THE 2018 INTERNATIONAL BUILDING CODE

ALL ELECTRICAL WORK MUST COMPLY WITH ALL REQUIREMENTS OF THE 2017 NATIONAL ELECTRICAL CODE

Subject: [Blank] ne of [Blank]
 I.C.C. Code [Blank] [Blank]
 Code [Blank] [Blank] [Blank]
 Code, and National Electrical Code.

PERMIT NO. NRB-078032-2024

DATE 2-6-2024

Lake County Building Division

By ED

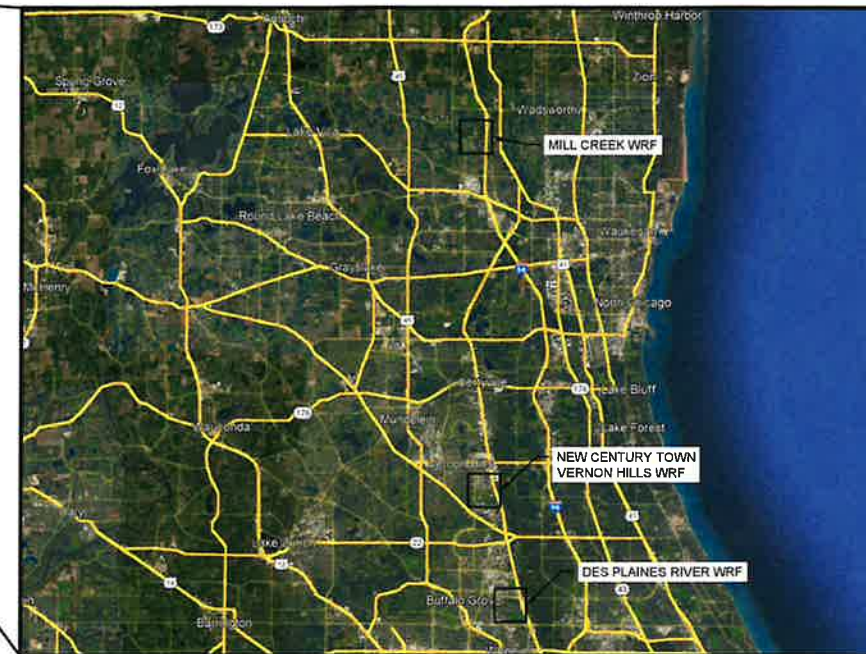

ILLINOIS

PROJECT LOCATIONS

LAKE COUNTY WATER RECLAMATION FACILITY INDEX		
NAME	ADDRESS	ABBREVIATION
DES PLAINES RIVER WATER RECLAMATION FACILITY	800 KRAUSE DR. BUFFALO GROVE, IL 60089	DPR
MILL CREEK WATER RECLAMATION FACILITY	16750 WEST ANCONA AVE. OLD MILL CREEK, IL 60083	MC
NEW CENTURY TOWN WATER RECLAMATION FACILITY	50 SOUTH AMERICAN WAY VERNON HILLS, IL 60061	NCT

SECURE A CERTIFICATE OF COMPLETION BEFORE OCCUPYING OR USING THIS STRUCTURE

PREPARED FOR



650 WEST WINCHESTER ROAD
LIBERTYVILLE, IL 60048
847-377-7500

PREPARED BY



3311 WEEDEN CREEK ROAD
SHEBOYGAN, WISCONSIN 53081
920-208-0296

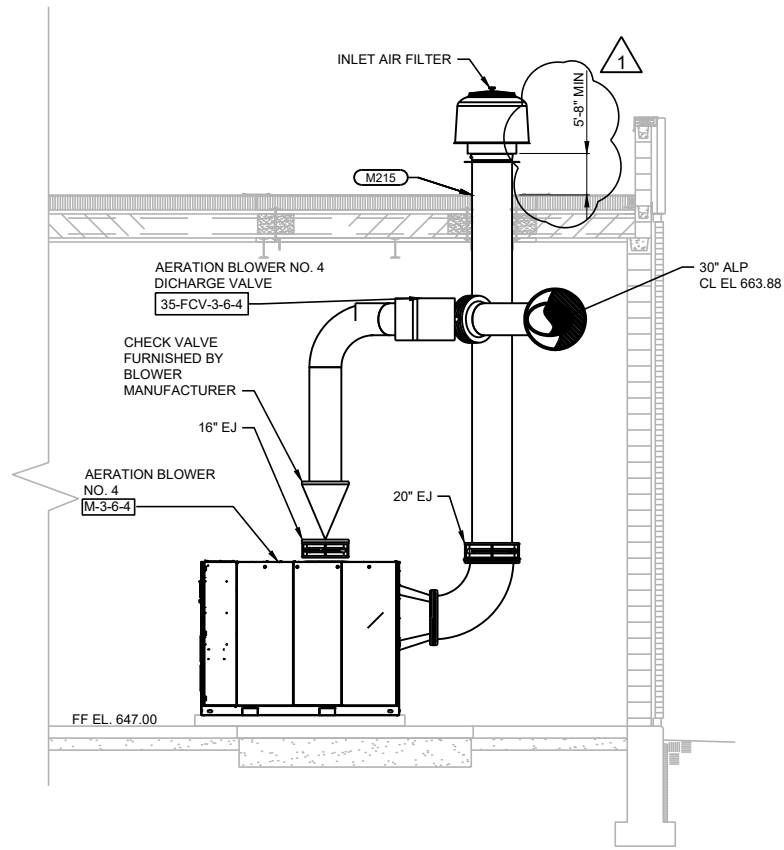

SECTION A
 0 1' 4'
 035-M-1
 035-M-2

GENERAL NOTES:

1. CONTRACTOR TO FIELD VERIFY EXISTING CONDITIONS, DIMENSIONS, AND ELEVATIONS PRIOR TO CONSTRUCTION AND/OR FABRICATION.
2. REFER TO 001 SERIES OF DRAWINGS FOR THE SPACE ENVIRONMENT/HAZARDOUS RATING SCHEDULE REGARDING ENVIRONMENTAL CONDITIONS ANTICIPATED WITHIN EACH SPACE AND ALLOWABLE MATERIALS OF CONSTRUCTION TO BE USED WITHIN EACH SPACE.
3. HAZARDOUS RATINGS IDENTIFIED ON THIS DRAWING INDICATE SPACES IN WHICH A HAZARDOUS ENVIRONMENT MAY GENERALLY EXIST. CONTRACTOR SHALL REFER TO SPACE ENVIRONMENT/HAZARDOUS RATING SCHEDULE IN 001 SERIES OF DRAWINGS FOR ADDITIONAL INFORMATION EXPLAINING THE EXTENT AND ENVELOPE ASSOCIATED WITH THESE HAZARDS.

Revision Number	Revision Description	Drawn By	Checked By	Date
1	ADDENDUM NO. 1	NMC	NMC	02/06/2024

Designed By	NMC
Drawn By	NMC
Checked By	WJR
Approved By	NWC
Filename	DPR35MS1.DWG
Project No.	14208
Project Date	JAN 2024

LAKE COUNTY DEPARTMENT OF PUBLIC WORKS
WRF IMPROVEMENTS
BLOWER REPLACEMENT

CONTRACT C
BATTERY B BLOWER BUILDING
SECTION



Sheet No.	79
Drawing No.	

035-M-3

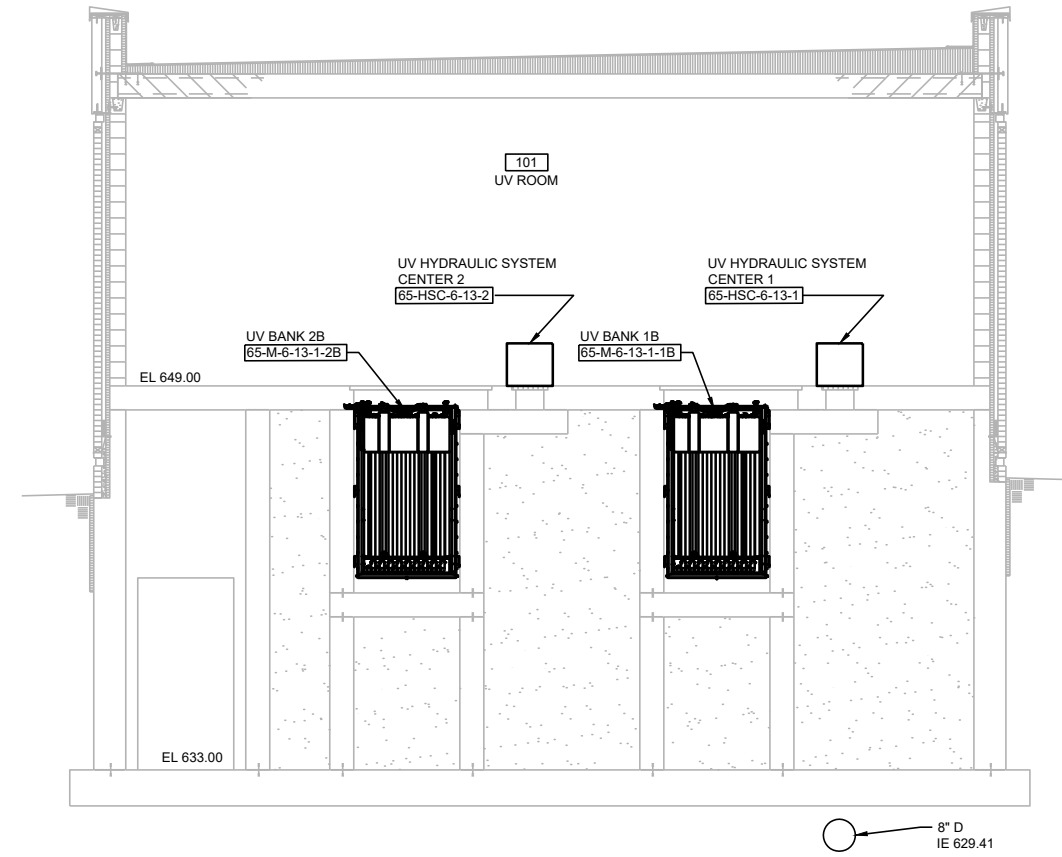

SECTION C
0 1' 4'
065-M-1
065-M-2

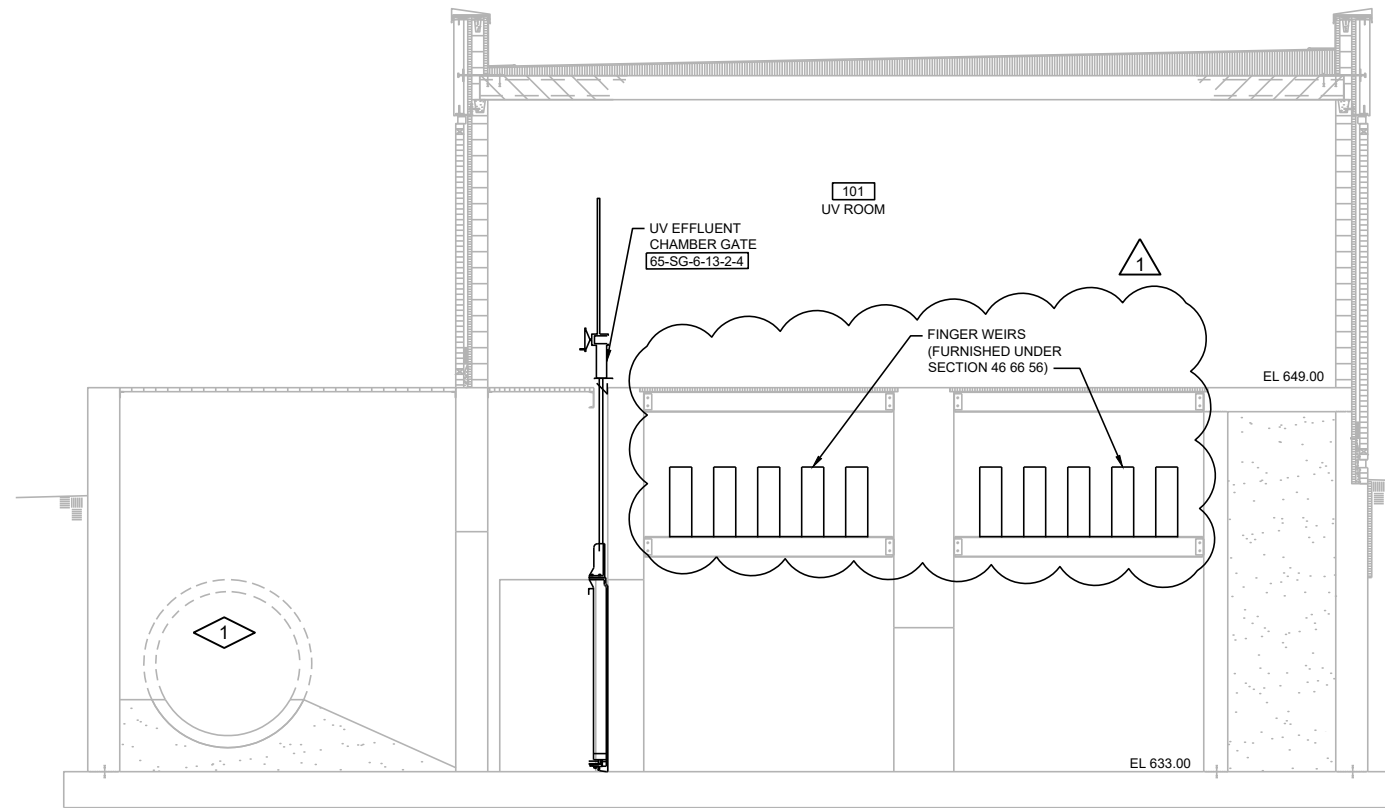

SECTION D
0 1' 4'
065-M-1
065-M-2

GENERAL NOTES:

- CONTRACTOR TO FIELD VERIFY EXISTING CONDITIONS, DIMENSIONS, AND ELEVATIONS PRIOR TO CONSTRUCTION AND/OR FABRICATION.
- REFER TO 001 SERIES OF DRAWINGS FOR THE SPACE ENVIRONMENT/HAZARDOUS RATING SCHEDULE REGARDING ENVIRONMENTAL CONDITIONS ANTICIPATED WITHIN EACH SPACE AND ALLOWABLE MATERIALS OF CONSTRUCTION TO BE USED WITHIN EACH SPACE.

PLAN NOTES:

- REMOVE TOP OF PIPE TO ALLOW FLOW FREELY FROM UV EFFLUENT DIVERSION BOX TO 72" EF. REMOVE MINIMUM OF 50% OF PIPE. REMOVAL TO OCCUR DURING SHUTDOWNS IN ACCORDANCE WITH 01 11 00-D.

Revision Number	Revision Description	Date
1	ADDENDUM NO. 1	02/06/2024

Designed By	NMC
Drawn By	NMC
Checked By	WJR
Approved By	NWC
Filename	065MP1.DWG
Project No.	14212
Project Date	JAN 2024

LAKE COUNTY DEPARTMENT OF PUBLIC WORKS
WRF IMPROVEMENTS
UV UPGRADE
CONTRACT D
UV DISINFECTION BUILDING
SECTIONS



Sheet No. 115
Drawing No.

065-M-4