

ASC/3-1000 CONTROLLER WITH:

- DATABASE: 7801
- SOFTWARE: V2.41.10
- ETHERNET MODULE

OVERLAPS

- IN EEPROM
- KEYBOARD ENTERED

A =
B =
C = 7
D =

ANALOG TELEMETRY MODULE: 32825G1

■ INTERNAL RS-232 TELEMETRY

TEST INPUT A =

TEST INPUT B =

LEGEND

BIU	BUS INTERFACE UNIT
BU()	C/C, BIU ()
CB()	CIRCUIT BREAKER ()
C/C	CONNECTING CABLE
CCA	CONTROLLER CABLE "A"
CDP	C/C, DR POWER
CMA	MMU/CMU CABLE "A"
CMB	MMU/CMU CABLE "B"
CPO	C/C PRE-EMPT OUTPUTS
CPP	C/C PRE-EMPT POWER
DR	DETECTOR RACK
DS()	DOOR SWITCH ()
FL()	FLASHER ()
FR()	FLASH XFER. RELAY
LS()	LOAD SWITCH
MC	MERCURY CONTACTOR
MP	MAIN PANEL
PAP	POWER-AUX PANEL
PSP	CAB. PWR. SUPPLY
SA	SURGE ARRESTOR
TB-()	TERM. BLOCK ()

MAIN PANEL PLUG-IN REQUIREMENTS

<input checked="" type="checkbox"/> BIU2 T&F	<input type="checkbox"/> BIU3 T&F	<input checked="" type="checkbox"/> LS9 PED 2 BEACONS	<input checked="" type="checkbox"/> LS10 PED 4 BEACONS	<input checked="" type="checkbox"/> LS11 PED 6 BEACONS	<input checked="" type="checkbox"/> LS12 PED 8 BEACONS	<input checked="" type="checkbox"/> LS13 OL "A"	<input checked="" type="checkbox"/> LS14 OL "B"	<input checked="" type="checkbox"/> LS15 OL "C"	<input checked="" type="checkbox"/> LS16 OL "D"
<input checked="" type="checkbox"/> BIU1 T&F	<input checked="" type="checkbox"/> LS1 VEH 1	<input checked="" type="checkbox"/> LS2 VEH 2	<input checked="" type="checkbox"/> LS3 VEH 3	<input checked="" type="checkbox"/> LS4 VEH 4	<input checked="" type="checkbox"/> LS5 VEH 5	<input checked="" type="checkbox"/> LS6 VEH 6	<input checked="" type="checkbox"/> LS7 VEH 7	<input checked="" type="checkbox"/> LS8 VEH 8	<input checked="" type="checkbox"/> FL1
<input checked="" type="checkbox"/> FR1 L R V1 V5	<input checked="" type="checkbox"/> FR2 L R V2 V6	<input checked="" type="checkbox"/> FR3 L R V3 V7	<input checked="" type="checkbox"/> FR4 L R V4 V8	<input checked="" type="checkbox"/> FR5 A C	<input checked="" type="checkbox"/> FR6 B D	<input checked="" type="checkbox"/> K1	<input checked="" type="checkbox"/> LS 24V CONT.		

■ DENOTES TYPE OF OPERATION AND/OR WHERE PLUG-IN IS REQUIRED. L = LEFT, R = RIGHT.
 ☒ DENOTES WHERE "UNUSED RED" JUMPER PART NUMBER 32448G1 IS REQUIRED. INSTALL BETWEEN PINS 1 & 3 FOR LOAD SWITCH OR PINS 6 & 8 AND 5 & 7 FOR FLASH TRANSFER RELAY.

FLASH:
 ø2&6 YELLOW, ALL OTHERS RED.
 ALL RED.
 RELAYS DE-ENERGIZED FOR FLASH.
 RELAYS ENERGIZED FOR FLASH.

FLASHER	
PIN	FUNCTION
7	CIRCUIT #1
8	CIRCUIT #2
9	CHASSIS GND
10	AC COMMON
11	115 VAC
12	-----

LOAD SWITCH	
PIN	FUNCTION
1	115 VAC
2	CHASSIS GND
3	RED/DW OUTPUT
4	-----
5	YEL OUTPUT
6	RED/DW INPUT
7	GRN/W OUTPUT
8	YEL INPUT
9	+24 VDC
10	GRN/W INPUT
11	AC COMMON
12	-----

①
2.2K
10W

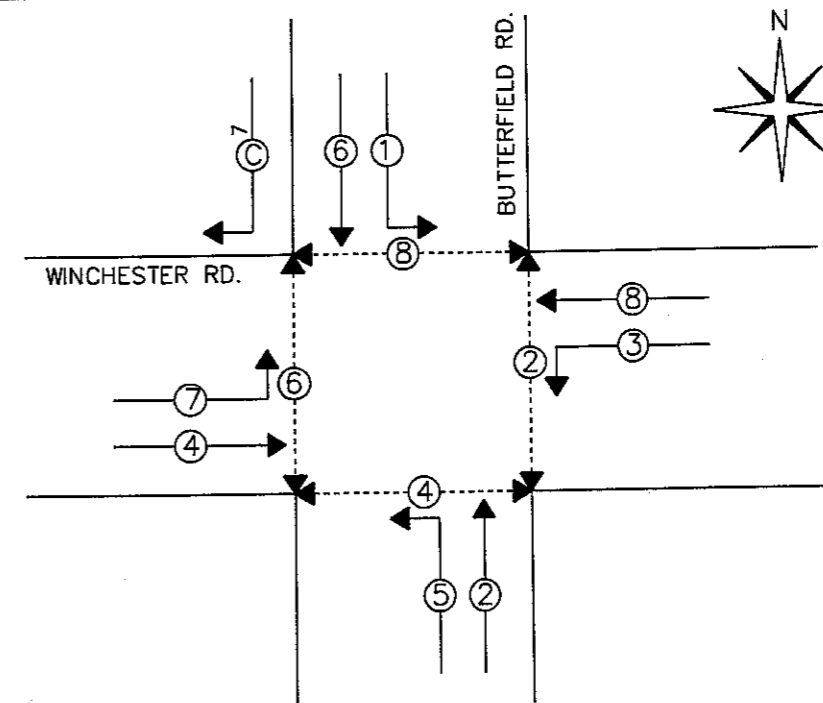

SHEET 1 OF 12

3 USE ONLY COPPER CONDUCTORS FOR FIELD AND SERVICE CONNECTIONS.

2 CONNECT A.C. SERVICE TO TERMINAL BLOCK 501 (LINE), 502 (NEUTRAL) AND GB2 (EARTH) ON RIGHT SIDEWALL OF CABINET.

① INSTALL 2.2K, 10 WATT LOAD RESISTORS BETWEEN PINS 7 AND 11 ON LOAD SWITCHES 9, 10, 11 & 12.

NOTES: UNLESS SPECIFIED OTHERWISE

DESIGNER G.V. T.C.C.	DATE 02/03/97	ECONOLITE CONTROL PRODUCTS INC.	TRAFFIC CONTROL CORPORATION	780 W. BELDEN SUITE D ADDISON, IL 60101
DRAWN CM TCC	03/24/08			CABINET SPECIFICATION: TS2TYPE1 2002 SPEC PLUG AND GO
CABINET SIZE 65" DBL DOOR		CUSTOMER: IDOT DIST. 1/LAKE COUNTY		FLASHER
INSPECTED		INTERSECTION: BUTTERFIELD RD. @ WINCHESTER RD.		SW.PACKS
APPROVED		LOCATION: LIBERTYVILLE		
CUSTOMER P.O. 3339	INSTALLED BY ERM	SALES ORDER NO. 104630B	SIZE B	DRAWING #TS20216PG-104630B BUTTERFIELD @ WINCHESTER

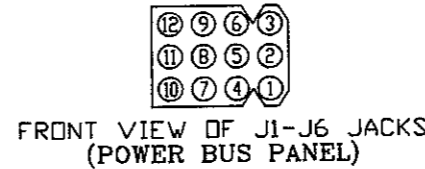
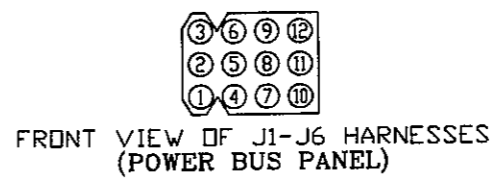
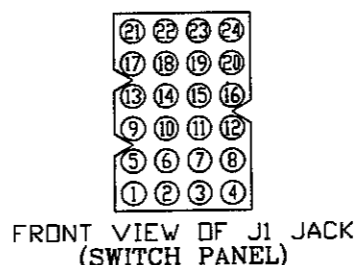
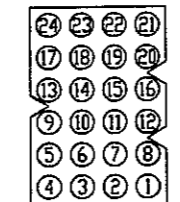
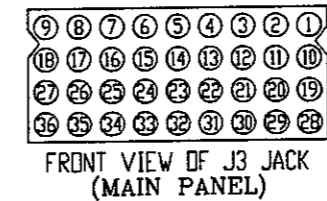
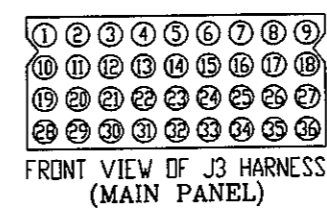
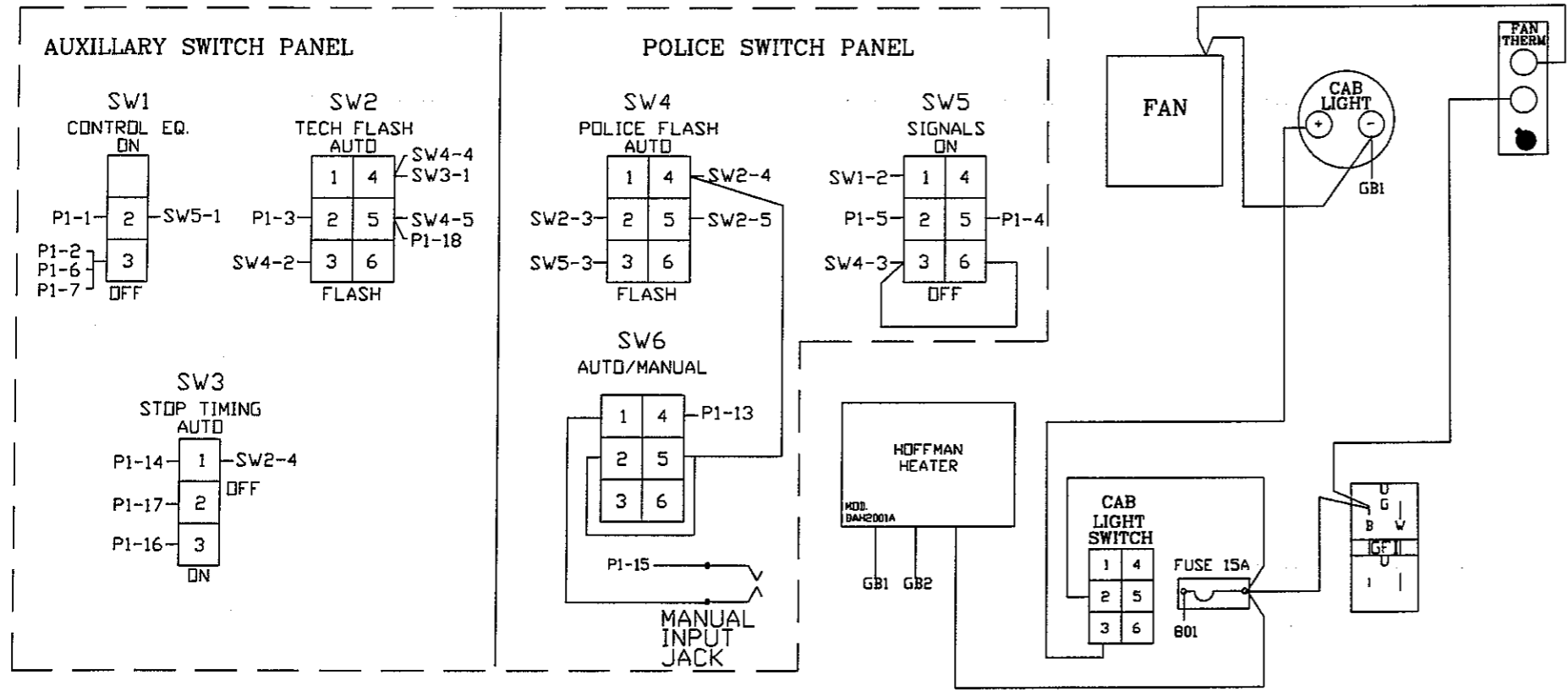

J3		P1	
J3-36	1 FILTER AC LINE (OUT)	P1-1	SW1-2
MMB-1	2 SWITCHED AC LINE (IN)	P1-2	SW1-3
MMA-37	3 FLASH CONTROL BUS (OUT)	P1-3	SW2-2
K1-10	4 SIGNAL BUS CONTROL (IN)	P1-4	SW5-5
FR6-2	5 FLASH RELAY CONTROL (IN)	P1-5	SW5-2
MMB-2	6 START DELAY AC BUS (IN)	P1-6	SW1-3
MMA-20	7 MMU FLASH CONTROL BUS (IN)	P1-7	SW1-3
	8 SPARE	P1-8	----
	9 SPARE	P1-9	----
	10 SPARE	P1-10	----
	11 SPARE	P1-11	----
	12 SPARE	P1-12	----
A-39	13 OPT-MANUAL CONT. ENABLE (IN)	P1-13	----
A-35	14 LOGIC GROUND	P1-14	SW3-1
A-40	15 OPT-INTERVAL ADVANCE (IN)	P1-15	----
A-31	16 MMU STOP TIME (OUT)	P1-16	SW3-3
A-30	17 CONTROLLER STOP TIME (IN)	P1-17	SW3-2
A-32	18 LOCAL FLASH STATUS (IN)	P1-18	SW2-5
A-38	19 OPT-COORD FREE (IN)	P1-19	----
A-33	20 OPT-ALARM 1 (IN)	P1-20	----
A-34	21 OPT-ALARM 2 (IN)	P1-21	----
K1-9	22 OPT-LOADSWITCH TEST (IN)	P1-22	----
B-3	23 MMU 24V MON. 2 (IN)	P1-23	----
B-4	24 +24 VDC	P1-24	----

TO POL/AUX P1

TO PB J1

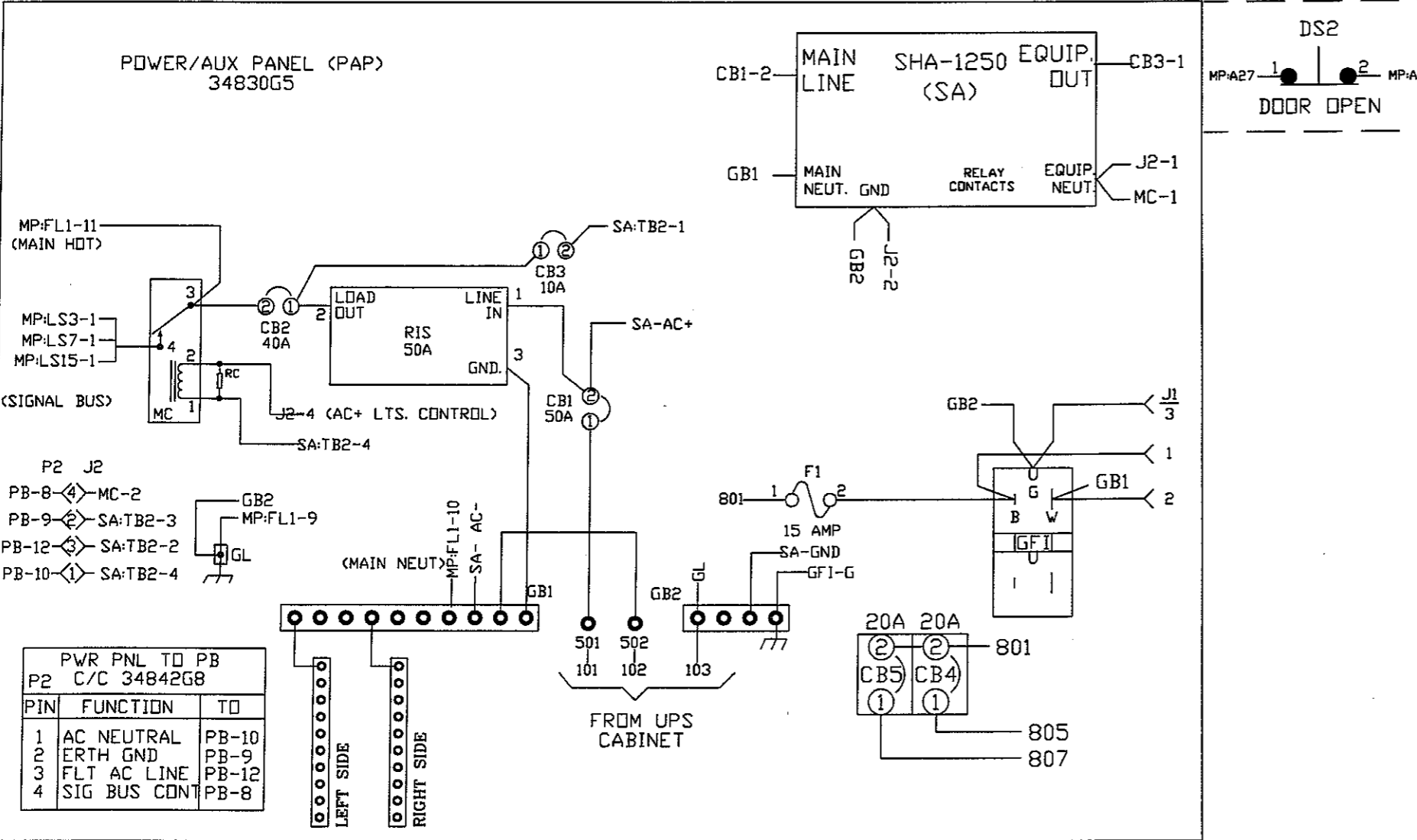

PWR PNL TO PB P2 C/C 34842G8		
PIN	FUNCTION	TO
1	AC NEUTRAL	PB-10
2	ERTH GND	PB-9
3	FLT AC LINE	PB-12
4	SIG BUS CDNT	PB-8

CONFIRMATION BEACONS

EVP 3 = N-SB
 EVP 4 = E-WB
 EVP 5 =
 EVP 6 =

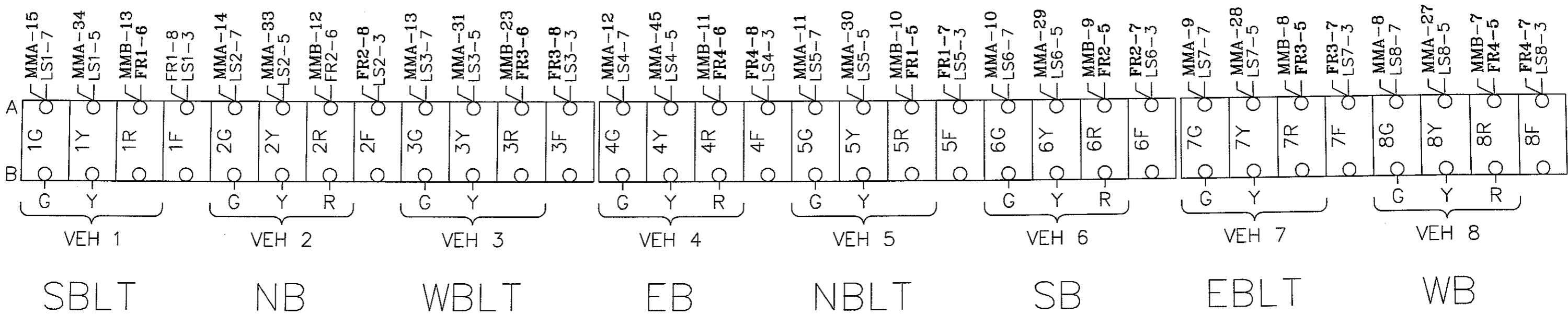
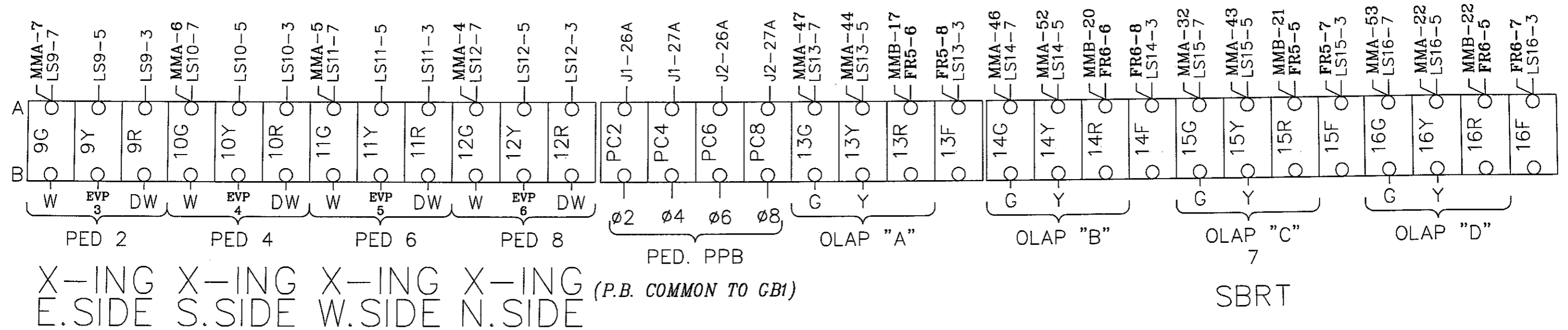

SIGNAL FIELD TERMINALS

* 2.2K
10W

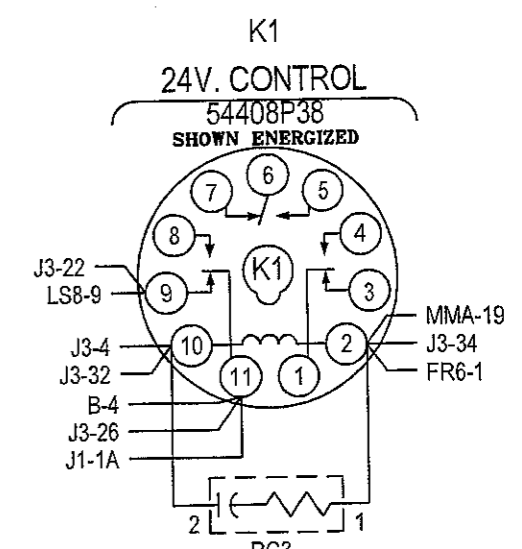
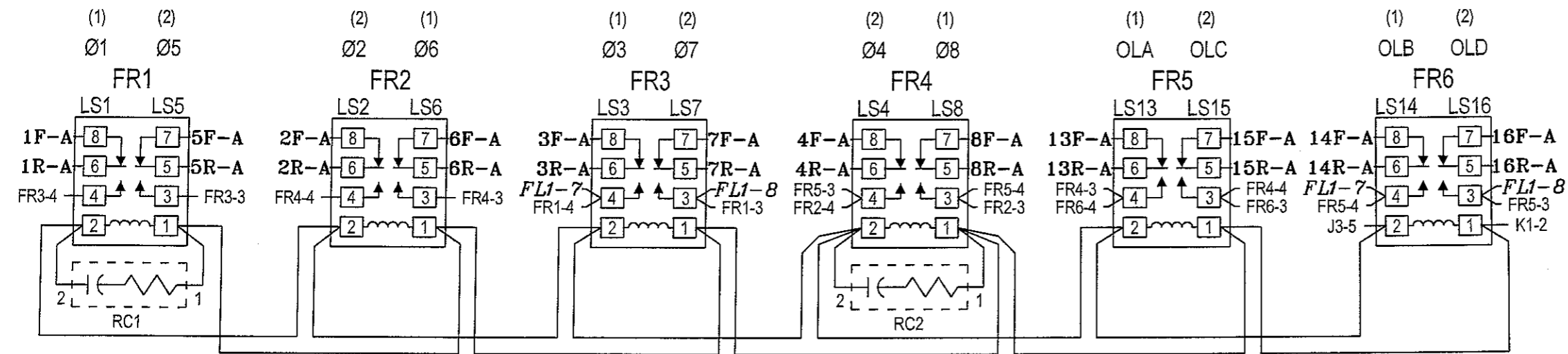
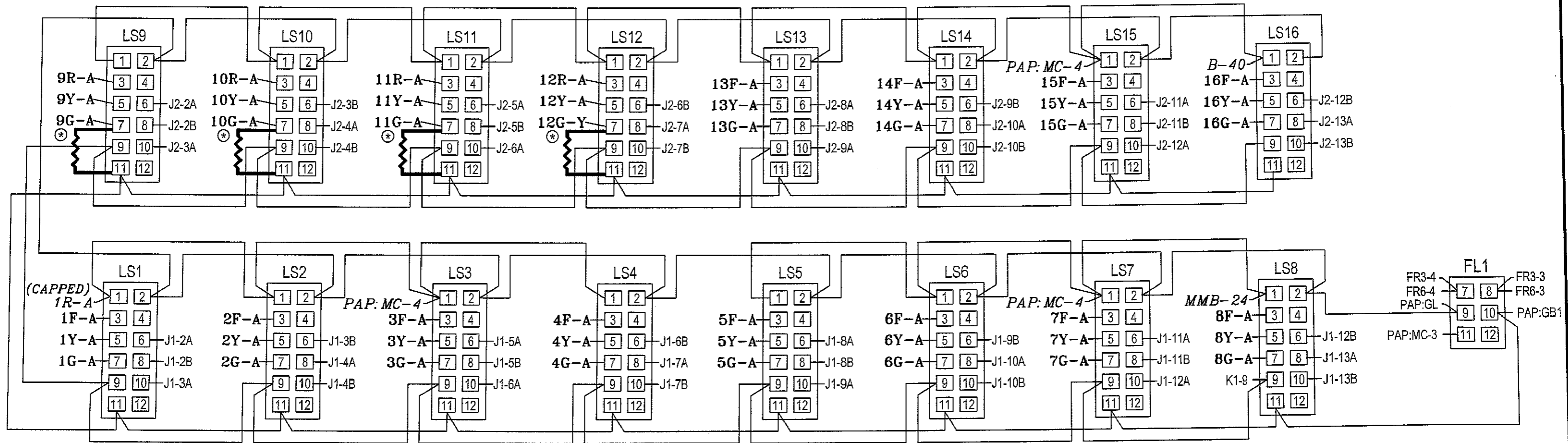

LOADBAY AND FLASH RELAYS

ALARM ASSIGNMENTS

OUTPUT	FUNCTION	TERMINATION
ALARM 1	DOOR OPEN	A33
ALARM 2	DN BATTERY	A34
ALARM 3	AC FAIL	A23
ALARM 4	UPS FAIL	A24

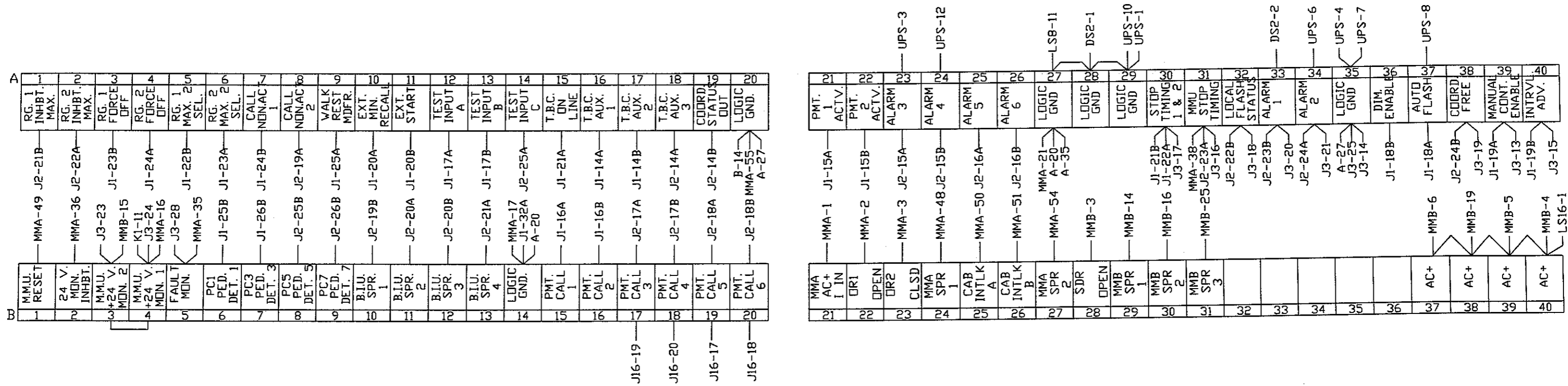

INTERFACE TERMINAL BLOCKS

J1 BIU #1		
PIN	FUNCTION	TO
1A	+24 VDC	K1-11
1B	+24 VDC	J2-1B
2A	LS1 RED	LS1-6
2B	LS1 YELLOW	LS1-8
3A	LS1 GREEN	LS1-10
3B	LS2 RED	LS2-6
4A	LS2 YELLOW	LS2-8
4B	LS2 GREEN	LS2-10
5A	LS3 RED	LS3-6
5B	LS3 YELLOW	LS3-8
6A	LS3 GREEN	LS3-10
6B	LS4 RED	LS4-6
7A	LS4 YELLOW	LS4-8
7B	LS4 GREEN	LS4-10
8A	LS5 RED	LS5-6
8B	LS5 YELLOW	LS5-8
9A	LS5 GREEN	LS5-10
9B	LS6 RED	LS6-6
10A	LS6 YELLOW	LS6-8
10B	LS6 GREEN	LS6-10
11A	LS7 RED	LS7-6
11B	LS7 YELLOW	LS7-8
12A	LS7 GREEN	LS7-10
12B	LS8 RED	LS8-6
13A	LS8 YELLOW	LS8-8
13B	LS8 GREEN	LS8-10
14A	TBC AUX 1	A-16
14B	TBC AUX 2	A-17
15A	PMT ACT 1	A-21
15B	PMT ACT 2	A-22
16A	PMT CALL 1	B-15
16B	PMT CALL 2	B-16
17A	TEST A	A-12
17B	TEST B	A-13
18A	AUTO FLASH	A-37
18B	DIM. ENABLE	A-36
19A	MANUAL CONT.	A-39
19B	INT. ADVANCE	A-40
20A	EXT. MIN. RECALL	A-10
20B	EXT. START	A-11
21A	TBC ONLINE	A-15
21B	STOP TIME (1)	A-30
22A	STOP TIME (2)	A-30
22B	MAX. 2 (1)	A-5
23A	MAX. 2 (2)	A-6
23B	FORCE OFF (1)	A-3
24A	FORCE OFF (2)	A-4
24B	CNA 1	A-7
25A	WALK REST MOD.	A-9
25B	PED. ISO. 1	B-6
26A	PED. ISO. 2	PC2-A
26B	PED. ISO. 3	B-7
27A	PED. ISO. 4	PC4-A
27B	PED. ISO. COMN.	J3-31
28A	ADDR. SEL. 0	---
28B	ADDR. SEL. 1	---
29A	ADDR. SEL. 2	---
29B	ADDR. SEL. 3	---
30A	RESERVED	---
30B	RESERVED	---
31A	EARTH GND.	LS12-2
31B	LINE FREQ. REF.	J3-29
32A	LOGIC GND.	B-14
32B	LOGIC GND.	J2-32A

J2 BIU #2		
PIN	FUNCTION	TO
1A	+24 VDC	J2-1B
1B	+24 VDC	J1-1B
2A	LS9 RED	LS9-6
2B	LS9 YELLOW	LS9-8
3A	LS9 GREEN	LS9-10
3B	LS10 RED	LS10-6
4A	LS10 YELLOW	LS10-8
4B	LS10 GREEN	LS10-10
5A	LS11 RED	LS11-6
5B	LS11 YELLOW	LS11-8
6A	LS11 GREEN	LS11-10
6B	LS12 RED	LS12-6
7A	LS12 YELLOW	LS12-8
7B	LS12 GREEN	LS12-10
8A	LS13 RED	LS13-6
8B	LS13 YELLOW	LS13-8
9A	LS13 GREEN	LS13-10
9B	LS14 RED	LS14-6
10A	LS14 YELLOW	LS14-8
10B	LS14 GREEN	LS14-10
11A	LS15 RED	LS15-6
11B	LS15 YELLOW	LS15-8
12A	LS15 GREEN	LS15-10
12B	LS16 RED	LS16-6
13A	LS16 YELLOW	LS16-8
13B	LS16 GREEN	LS16-10
14A	TBC AUX 3	A-18
14B	COORD. STATUS	A-19
15A	ALARM 3	A-23
15B	ALARM 4	A-24
16A	ALARM 5	A-25
16B	ALARM 6	A-26
17A	PMT CALL 3	B-17
17B	PMT CALL 4	B-18
18A	PMT CALL 5	B-19
18B	PMT CALL 6	B-20
19A	CNA 2	A-8
19B	SPARE 1	B-10
20A	SPARE 2	B-11
20B	SPARE 3	B-12
21A	SPARE 4	B-13
21B	INHIBIT MAX (1)	A-1
22A	INHIBIT MAX (2)	A-2
22B	LOCAL FLASH	A-32
23A	MMU FLASH	A-31
23B	ALARM 1	A-33
24A	ALARM 2	A-34
24B	COORD FREE IN	A-38
25A	TEST C	A-14
25B	PED. ISO. 5	B-8
26A	PED. ISO. 6	PC6-A
26B	PED. ISO. 7	B-9
27A	PED. ISO. 8	PC8-A
27B	PED. ISO. COMN.	J1-27B
28A	ADDR. SEL. 0	J2-32A
28B	ADDR. SEL. 1	---
29A	ADDR. SEL. 2	---
29B	ADDR. SEL. 3	---
30A	RESERVED	---
30B	RESERVED	---
31A	EARTH GND.	J1-31A
31B	LINE FREQ. REF.	J1-31B
32A	LOGIC GND.	J1-32B
32B	LOGIC GND.	J2-32A

MAIN PANEL CONTROL POWER C/C 34842G4	
PIN	FUNCTION
1	LOGIC GROUND
2	+24 VDC (IN)
3	---
4	MMU FAULT MONITOR (IN)
5	LINE FREQ. REFERENCE (IN)
6	---
7	+12 VAC (IN)
8	SIGNAL BUS CONTROL (IN)
9	---
10	FILTERED AC NEUTRAL (IN)
11	CONT. EQUIP. AC LINE (OUT)
12	FILTERED AC LINE (IN)

CONTROLLER POWER (CCA2) C/C 34842G3			
WIRE	PIN	SIGNAL	TO
1	A	FAULT MONITOR	PB-4
2	U	AC NEUTRAL	PB-10
3	V	EARTH GROUND	PB-9
4	W	LOGIC GROUND	PB-1
5	P	AC LINE	PB-11
6	SHL	EARTH GROUND	CCA2-V

TYPE 1 CONTROLLER POWER C/C 34842G2		
PIN	FUNCTION	TO
A	AC NEUTRAL	PB-10
B	---	---
C	AC LINE	PB-11
D	---	---
E	+12 VDC	PB-3
F	+24 VDC	PB-2
G	---	---
H	FAULT MON.	PB-4
I	LOGIC GND.	PB-1
J	EARTH GND.	PB-9
K	---	---
L	---	---
M	---	---
N	---	---
O	---	---
P	---	---
Q	---	---
R	---	---
S	---	---
T	---	---
U	---	---
V	---	---
W	---	---
X	---	---
Y	---	---
Z	---	---
SHL	EARTH GND.	PIN H

CABINET POWER SUPPLY C/C 34842G1		
PIN	FUNCTION	TO
A	AC NEUTRAL	PB-10
B	LINE FREQUENCY REF.	PB-5
C	AC LINE	PB-11
D	---	---
E	+12 VDC	PB-3
F	+24 VDC	PB-2
G	---	---
H	RESERVED	---
I	LOGIC GND.	PB-1
J	EARTH GND.	PB-9
K	+12 VAC	PB-7
L	RESERVED	---
M	---	---
N	---	---
O	---	---
P	---	---
Q	---	---
R	---	---
S	---	---
T	---	---
U	---	---
V	---	---
W	---	---
X	---	---
Y	---	---
Z	---	---
SHL	EARTH GND.	PIN H

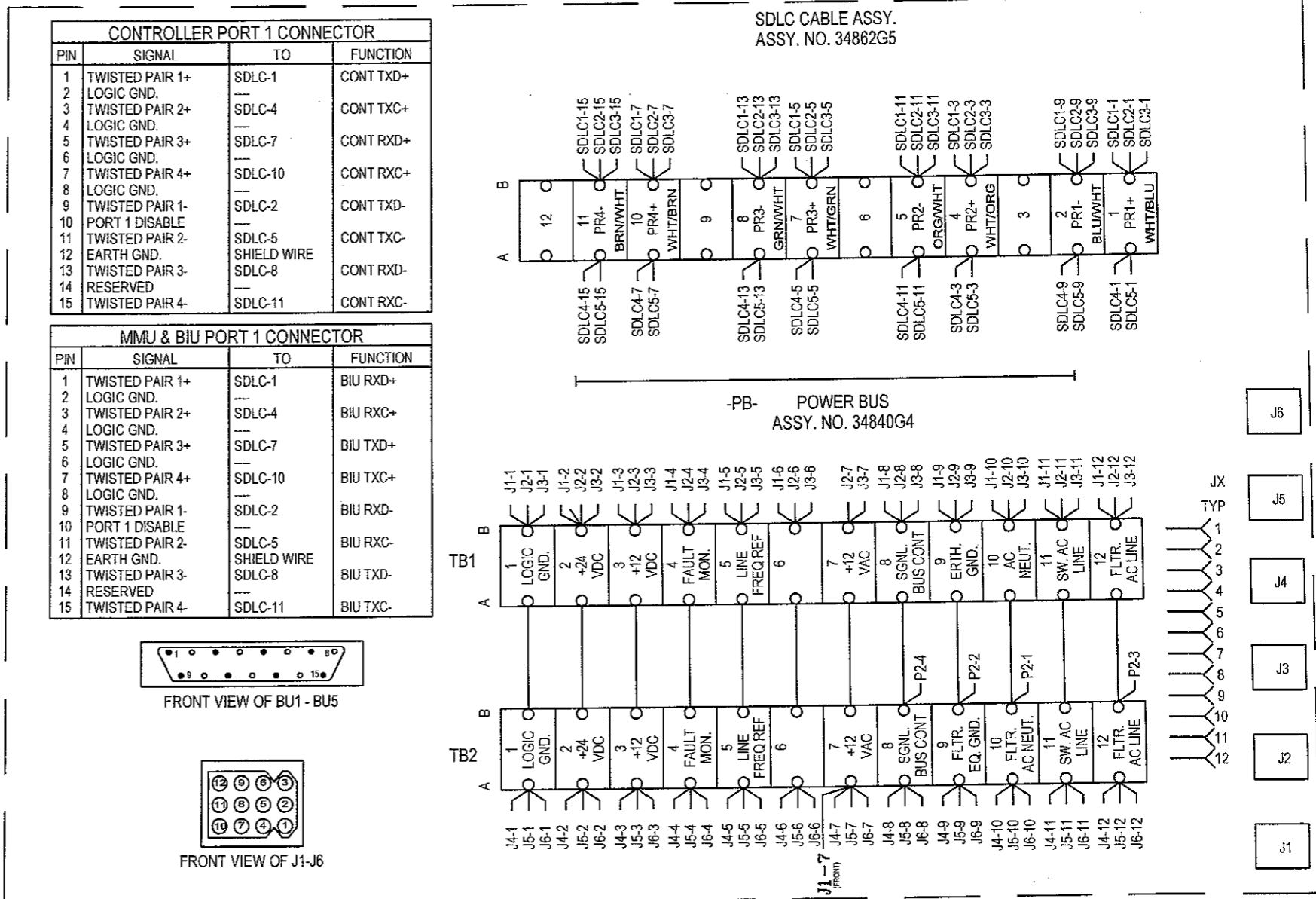

BIU AND CONNECTING CABLES

WIRE LIST FOR NEMA MALFUNCTION MANAGEMENT UNIT

CONNECTOR "A" (MMA)					CONNECTOR "B" (MMB)				
PIN	WIRE	MON. FUNCTION	TO	SIG. FUNCTION	PIN	WIRE	MON. FUNCTION	TO	SIG. FUNCTION
A	A-1	AC+ I INPUT	B21		A	B-1	AC+ II INPUT	J3-2	MMU POWER
B	A-2	OUT RLY 1 OPEN	B22		B	B-2	S. DLY RLY COMM.	J3-6	MMU POWER
C	A-3	OUT RLY 2 CLSD	B23		C	B-3	S. DLY RLY OPEN	B28	
D	A-4	CH. 12 GREEN	12G-A	[^] 8 WLK	D	B-4	CH. 12 RED	B40	
E	A-5	CH. 11 GREEN	11G-A	[^] 6 WLK	E	B-5	CH. 11 RED	B39	
F	A-6	CH. 10 GREEN	10G-A	[^] 4 WLK	F	B-6	CH. 9 RED	B37	
G	A-7	CH. 9 GREEN	9G-A	[^] 2 WLK	G	B-7	CH. 8 RED	8R-A	[^] 8 RED
H	A-8	CH. 8 GREEN	8G-A	[^] 8 GRN	H	B-8	CH. 7 RED	7R-A	[^] 7 RED
J	A-9	CH. 7 GREEN	7G-A	[^] 7 GRN	J	B-9	CH. 6 RED	6R-A	[^] 6 RED
K	A-10	CH. 6 GREEN	6G-A	[^] 6 GRN	K	B-10	CH. 5 RED	5R-A	[^] 5 RED
L	A-11	CH. 5 GREEN	5G-A	[^] 5 GRN	L	B-11	CH. 4 RED	4R-A	[^] 4 RED
M	A-12	CH. 4 GREEN	4G-A	[^] 4 GRN	M	B-12	CH. 2 RED	2R-A	[^] 2 RED
N	A-13	CH. 3 GREEN	3G-A	[^] 3 GRN	N	B-13	CH. 1 RED	1R-A	[^] 1 RED
P	A-14	CH. 2 GREEN	2G-A	[^] 2 GRN	P	B-14	(SPARE 1)	B29	
R	A-15	CH. 1 GREEN	1G-A	[^] 1 GRN	R	B-15	+24V MONITOR II	B-3	+24V MON. II
S	A-16	+24V MON. I	B-4	LS +24V MON.	S	B-16	(SPARE 2)	B30	
T	A-17	LOGIC GND	B-14	LOGIC GND	T	B-17	CH. 13 RED	13R-A	OLA RED
U	A-18	CHASSIS GND	LS7-2	EARTH GND.	U	B-18	S. DLY RLY CLSD	J3-35	CONT. POWER
V	A-19	AC- (COMMON)	K1-2	AC NEUTRAL	V	B-19	CH. 10 RED	B38	
W	A-20	OUT RLY 1 COM.	J3-7	SIG BUS CONT	W	B-20	CH. 14 RED	14R-A	OLB RED
X	A-21	OUT RLY 2 COM.	A-27	LOGIC GND	X	B-21	CH. 15 RED	15R-A	OLC RED
Y	A-22	CH. 12 YELLOW	-T-		Y	B-22	CH. 16 RED	16R-A	OLD RED
Z	A-23	CH. 11 YELLOW	-T-		Z	B-23	CH. 3 RED	3R-A	[^] 3 RED
a	A-24	CH. 10 WALK	---		a	B-24	RED ENABLE	LS8-1	SIG BUS CON.
b	A-25	CH. 10 YELLOW	-T-		b	B-25	(SPARE 3)	B31	
c	A-26	CH. 9 YELLOW	-T-		c	B-26	LOCAL FLASH IN	CAPPED	POL/AX FLSH
d	A-27	CH. 8 YELLOW	8Y-A	[^] 8 YEL		B-27	SHELL GROUND	LS6-2	EARTH GND.
e	A-28	CH. 7 YELLOW	7Y-A	[^] 7 YEL					
f	A-29	CH. 6 YELLOW	6Y-A	[^] 6 YEL					
g	A-30	CH. 5 YELLOW	5Y-A	[^] 5 YEL					
h	A-31	CH. 3 YELLOW	3Y-A	[^] 3 YEL					
i	A-32	CH. 15 GREEN	15G-A	OLC GRN					
j	A-33	CH. 2 YELLOW	2Y-A	[^] 2 YEL					
k	A-34	CH. 1 YELLOW	1Y-A	[^] 1 YEL					
m	A-35	CONT. VOLT. MON.	B-5	VOLT. MON.					
n	A-36	+24V MON. INH.	B-2						
p	A-37	OUT RLY 1 CLSD	J3-3						
q	A-38	OUT RLY 2 OPEN	A-31	STOP TIME					
r	A-39	CH. 12 WALK	---						
s	A-40	CH. 11 WALK	---						
t	A-41	CH. 9 WALK	---						
u	A-42	CH. 16 YELLOW	16Y-A	OLD YEL					
v	A-43	CH. 15 YELLOW	15Y-A	OLC YEL					
w	A-44	CH. 13 YELLOW	13Y-A	OLA YEL					
x	A-45	CH. 4 YELLOW	4Y-A	[^] 4 YEL					
y	A-46	CH. 14 GREEN	14G-A	OLB GRN					
z	A-47	CH. 13 GREEN	13G-A	OLA GRN					
AA	A-48	(SPARE 1)	B24						
BB	A-49	RESET	B-1						
CC	A-50	CAB. INTLK A	B25						
DD	A-51	CAB. INTLK B	B26						
EE	A-52	CH. 14 YELLOW	14Y-A	OLB YRL					
FF	A-53	CH. 16 GREEN	16G-A	OLD GRN					
GG	A-54	(SPARE 2)	B27						
HH	A-55	TYPE SELECT	A-20	MMU/CMU SEL.					
	A-56	SHELL GND	LS15-2	EARTH GND.					

NOTES FOR 16 CHANNEL M.M.U.

- (1) RELAY CONTACT POSITIONS SPECIFIED ARE FOR NON-CONFLICT MODE.
- (2) TO PROGRAM MMU, SOLDER JUMPERS IN PROGRAMMING CARD FOR ALL PERMISSABLE PHASE MOVEMENTS, MINIMUM CHANGE DISABLE FOR ALL PEDESTRIAN CHANNELS, AND MIN. FLASH, VOLTAGE MON., AND 24V. MON. LATCH OPTIONS AS DESIRED.

M.M.U. CHANNEL ASSIGNMENTS

CH. 1 =	L/S 1 =	[^] 1 VEH.
CH. 2 =	L/S 2 =	[^] 2 VEH.
CH. 3 =	L/S 3 =	[^] 3 VEH.
CH. 4 =	L/S 4 =	[^] 4 VEH.
CH. 5 =	L/S 5 =	[^] 5 VEH.
CH. 6 =	L/S 6 =	[^] 6 VEH.
CH. 7 =	L/S 7 =	[^] 7 VEH.
CH. 8 =	L/S 8 =	[^] 8 VEH.
CH. 9 =	L/S 9 =	[^] 2 PED.
CH. 10 =	L/S 10 =	[^] 4 PED.
CH. 11 =	L/S 11 =	[^] 6 PED.
CH. 12 =	L/S 12 =	[^] 8 PED.
CH. 13 =	L/S 13 =	OLAP A
CH. 14 =	L/S 14 =	OLAP B
CH. 15 =	L/S 15 =	OLAP C
CH. 16 =	L/S 16 =	OLAP D

MMU PROGRAM CARD

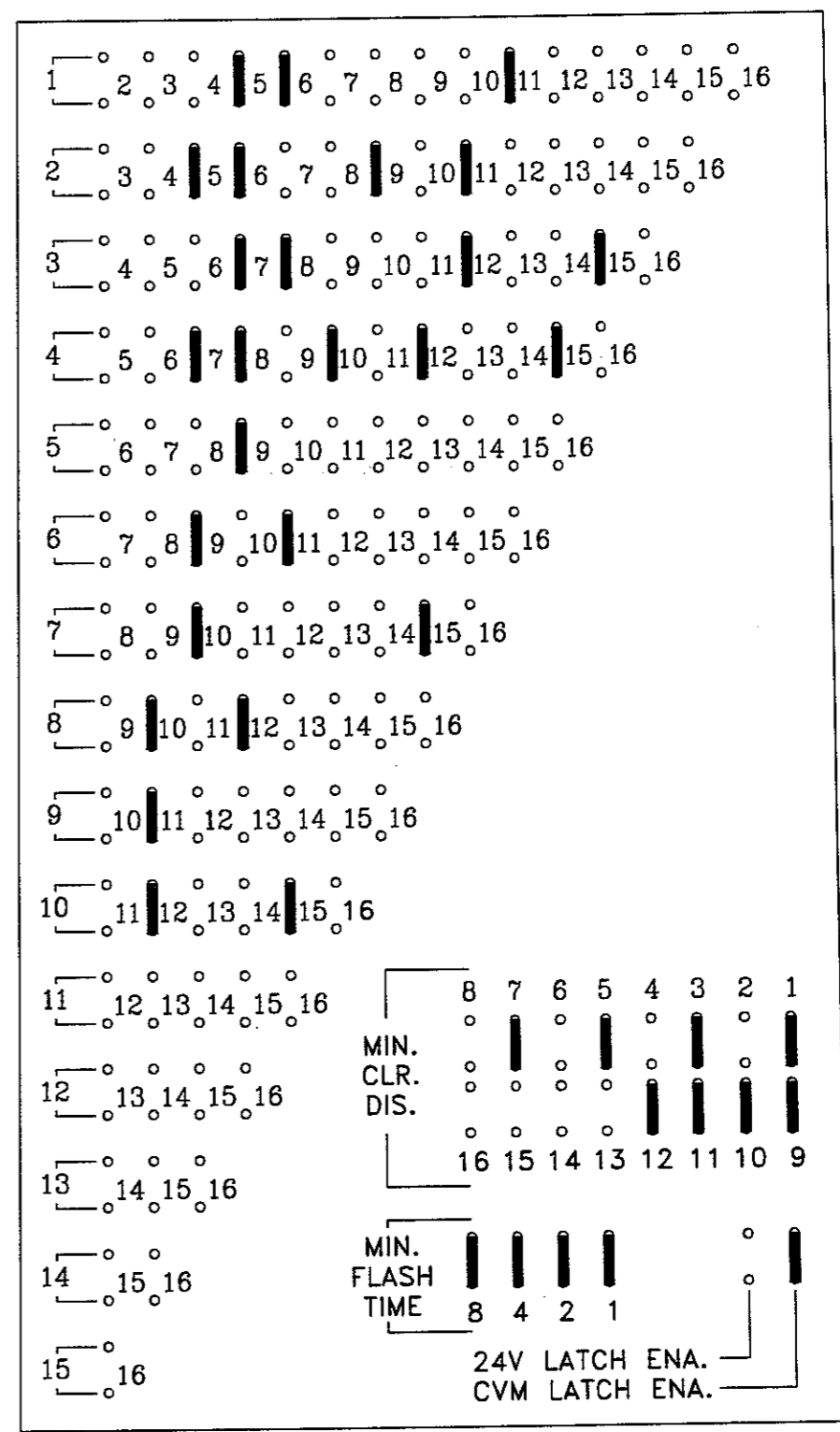

M.M.U. C/C'S AND PROGRAM CARD

DETECTOR RACK 34030G1

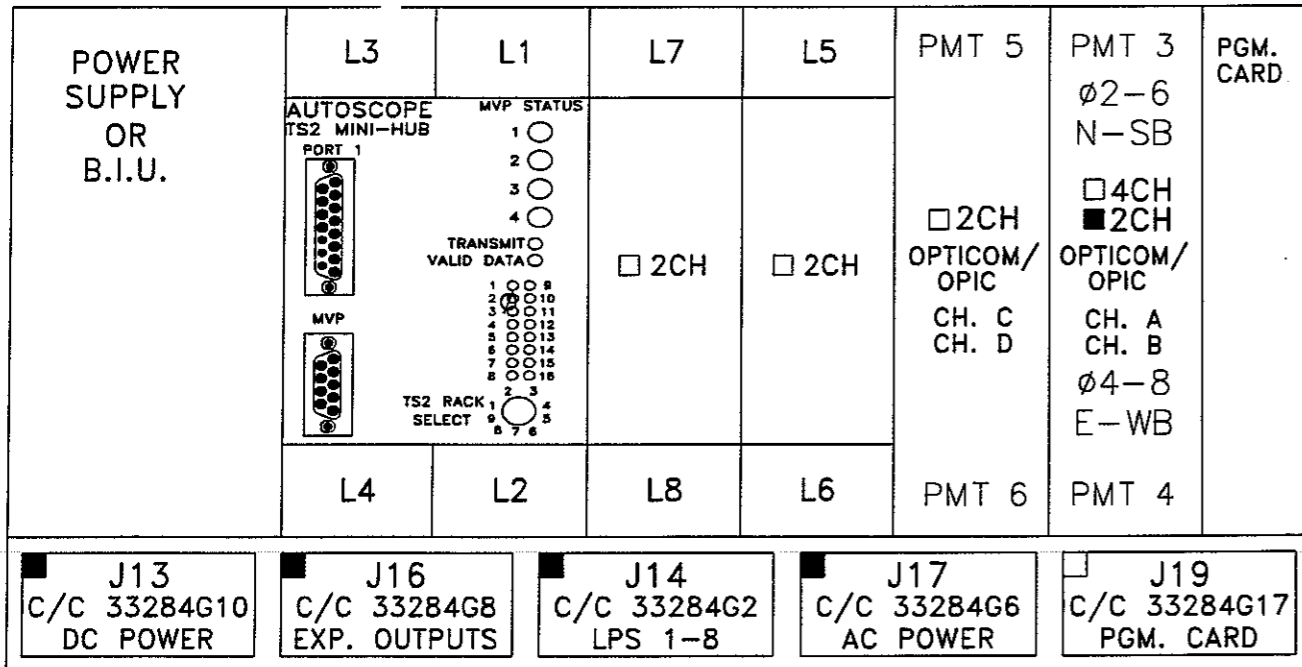

①

ADDRESS TABLE					
RACK #	JMPR	DET. #S	RACK #	JMPR	DET. #S
1	<input type="checkbox"/> <input type="checkbox"/> <input type="checkbox"/> <input type="checkbox"/>	1-16	5	<input type="checkbox"/> <input type="checkbox"/> <input type="checkbox"/> <input type="checkbox"/>	65-80
2	<input type="checkbox"/> <input type="checkbox"/> <input type="checkbox"/> <input type="checkbox"/>	17-32	6	<input type="checkbox"/> <input type="checkbox"/> <input type="checkbox"/> <input type="checkbox"/>	81-96
3	<input type="checkbox"/> <input type="checkbox"/> <input type="checkbox"/> <input type="checkbox"/>	33-48	7	<input type="checkbox"/> <input type="checkbox"/> <input type="checkbox"/> <input type="checkbox"/>	97-112
4	<input type="checkbox"/> <input type="checkbox"/> <input type="checkbox"/> <input type="checkbox"/>	49-64	8	<input type="checkbox"/> <input type="checkbox"/> <input type="checkbox"/> <input type="checkbox"/>	113-128

DETECTOR LAYOUT

WINCHESTER RD.

BUTTERFIELD RD.

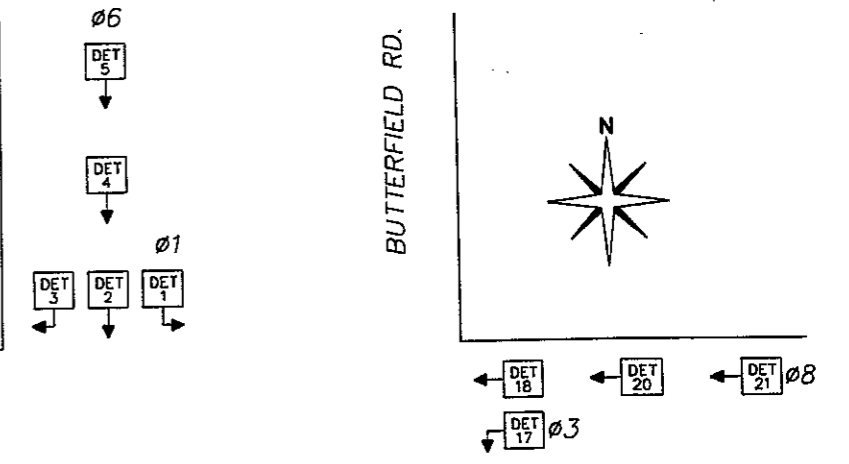
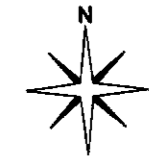

*DETECTOR DELAY & EXTENSION VALUES SHOWN ARE TYPICAL

RACK # 1

RACK # 2

RACK # 3
(LOOP RACK)

DETECTOR ASSIGNMENTS					DETECTOR ASSIGNMENTS					DETECTOR ASSIGNMENTS				
CONT. INPUT	PHASE ASGN.	DET. TYPE	* DET. EXT.	* DET. DLY.	CONT. INPUT	PHASE ASGN.	DET. TYPE	* DET. EXT.	* DET. DLY.	CONT. INPUT	PHASE ASGN.	DET. TYPE	* DET. EXT.	* DET. DLY.
1	1	1	1.0	2.0	17	3	1	1.0	2.0	33				
2	6	5	2.5	2.0	18	8	1	3.0	2.0	34				
3	6	5	2.5	8.0	19					35				
4	6	1	2.5	0.0	20	8	1	2.5	0.0	36				
5	6	1	2.5	0.0	21	8	1	2.5	0.0	37				
6					22					38				
7					23					39				
8					24					40				
9	5	1	1.0	2.0	25	7	1	1.0	2.0	41				
10	2	5	2.5	2.0	26	4	1	3.0	2.0	42				
11					27					43				
12	2	1	2.5	0.0	28	4	1	2.5	0.0	44				
13	2	1	2.5	0.0	29	4	1	2.5	0.0	45				
14					30					46				
15					31					47				
16					32					48				

DETECTOR RACK PROGRAMMING JUMPERS																													
DET. TYPE	JP1	JP2	SLOT 1/2 ①						SLOT 3/4 ①						SLOT 5/6 ①						SLOT 7/8 ①								
			JP3	JP4	JP5	JP6	JP7	JP8	JP9	JP10	JP11	JP12	JP13	JP14	JP15	JP16	JP17	JP18	JP19	JP20	JP21	JP22	JP23	JP24	JP25	JP26	JP27	JP28	JP29
① TS-1	NO	NO	<input type="checkbox"/>	<input type="checkbox"/>	<input type="checkbox"/>	<input type="checkbox"/>	<input type="checkbox"/>	<input type="checkbox"/>	<input type="checkbox"/>	<input type="checkbox"/>	<input type="checkbox"/>	<input type="checkbox"/>	<input type="checkbox"/>	<input type="checkbox"/>	<input type="checkbox"/>	<input type="checkbox"/>	<input type="checkbox"/>	<input type="checkbox"/>	<input type="checkbox"/>	<input type="checkbox"/>	<input type="checkbox"/>	<input type="checkbox"/>	<input type="checkbox"/>	<input type="checkbox"/>	<input type="checkbox"/>	<input type="checkbox"/>	<input type="checkbox"/>	<input type="checkbox"/>	<input type="checkbox"/>
② TS-2	YES	YES	<input type="checkbox"/>	<input type="checkbox"/>	<input type="checkbox"/>	<input type="checkbox"/>	<input type="checkbox"/>	<input type="checkbox"/>	<input type="checkbox"/>	<input type="checkbox"/>	<input type="checkbox"/>	<input type="checkbox"/>	<input type="checkbox"/>	<input type="checkbox"/>	<input type="checkbox"/>	<input type="checkbox"/>	<input type="checkbox"/>	<input type="checkbox"/>	<input type="checkbox"/>	<input type="checkbox"/>	<input type="checkbox"/>	<input type="checkbox"/>	<input type="checkbox"/>	<input type="checkbox"/>	<input type="checkbox"/>	<input type="checkbox"/>	<input type="checkbox"/>	<input type="checkbox"/>	<input type="checkbox"/>
③ M-632T 262-FC	NO	NO	<input type="checkbox"/>	<input type="checkbox"/>	<input type="checkbox"/>	<input type="checkbox"/>	<input type="checkbox"/>	<input type="checkbox"/>	<input type="checkbox"/>	<input type="checkbox"/>	<input type="checkbox"/>	<input type="checkbox"/>	<input type="checkbox"/>	<input type="checkbox"/>	<input type="checkbox"/>	<input type="checkbox"/>	<input type="checkbox"/>	<input type="checkbox"/>	<input type="checkbox"/>	<input type="checkbox"/>	<input type="checkbox"/>	<input type="checkbox"/>	<input type="checkbox"/>	<input type="checkbox"/>	<input type="checkbox"/>	<input type="checkbox"/>	<input type="checkbox"/>	<input type="checkbox"/>	<input type="checkbox"/>
④ MAG.	NO	NO	<input type="checkbox"/>	<input type="checkbox"/>	<input type="checkbox"/>	<input type="checkbox"/>	<input type="checkbox"/>	<input type="checkbox"/>	<input type="checkbox"/>	<input type="checkbox"/>	<input type="checkbox"/>	<input type="checkbox"/>	<input type="checkbox"/>	<input type="checkbox"/>	<input type="checkbox"/>	<input type="checkbox"/>	<input type="checkbox"/>	<input type="checkbox"/>	<input type="checkbox"/>	<input type="checkbox"/>	<input type="checkbox"/>	<input type="checkbox"/>	<input type="checkbox"/>	<input type="checkbox"/>	<input type="checkbox"/>	<input type="checkbox"/>	<input type="checkbox"/>	<input type="checkbox"/>	<input type="checkbox"/>

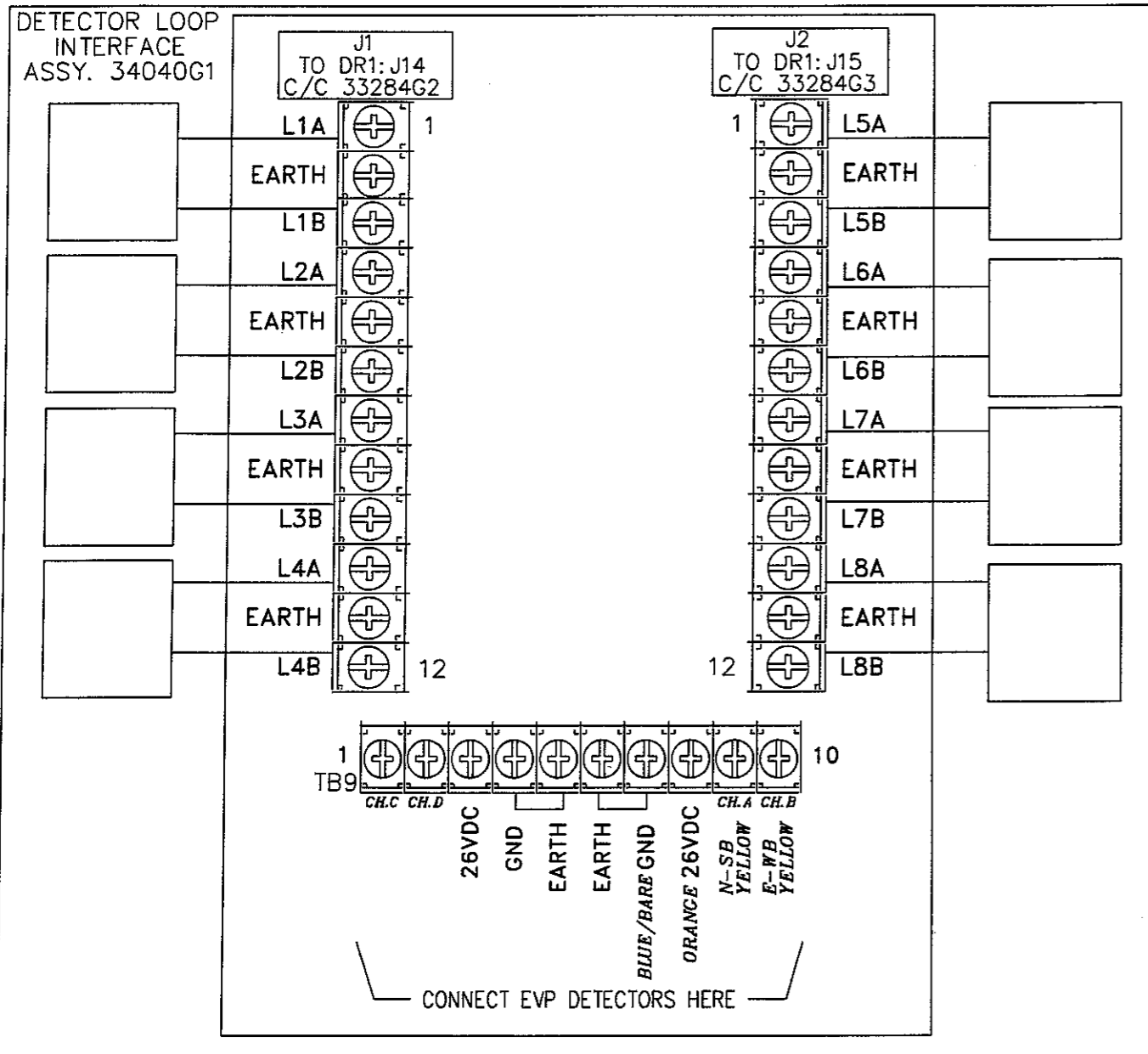

DET. LOOPS 1-8 (J14) C/C 33284G2

PIN	SIGNAL	TO
1	LOOP 1+	LPI1: TB1-1
2	LOOP 1-	LPI1: TB1-3
3	LOOP 2+	LPI1: TB1-4
4	LOOP 2-	LPI1: TB1-6
5	LOOP 3+	LPI1: TB1-7
6	LOOP 3-	LPI1: TB1-9
7	LOOP 4+	LPI1: TB1-10
8	LOOP 4-	LPI1: TB1-12
9	LOOP 5+	LPI1: TB5-1
10	LOOP 5-	LPI1: TB5-3
11	LOOP 6+	LPI1: TB5-4
12	LOOP 6-	LPI1: TB5-6
13	LOOP 7+	LPI1: TB5-7
14	LOOP 7-	LPI1: TB5-9
15	LOOP 8+	LPI1: TB5-10
16	LOOP 8-	LPI1: TB5-12
17	PMT. DET. CH. C	LPI1: TB9-1
18	PMT. DET. CH. D	LPI1: TB9-2
19	KEY PIN	
20	PMT. CH. C/D +26VDC	LPI1: TB9-3
21	PMT. DC GROUND	LPI1: TB9-4,7
22	PMT. CH. A/B +26VDC	LPI1: TB9-8
23	PMT. DET. CH. A	LPI1: TB9-9
24	PMT. DET. CH. B	LPI1: TB9-10
25	----	
26	----	

DET. RACK POWER
C/C 34842G5

P1/ DR: J13	P2/ DR: J17	FUNCTION	TO
1		+12 VDC (DET. POWER)	PB-3
2		+24 VDC (BIU POWER)	PB-2
3		LOGIC GROUND	PB-1
4		EARTH GROUND	PB-9
5		"KEY PIN"	
6		LINE FREQUENCY REF.	PB-5
	1	EARTH GROUND	----
	2	AC LINE	PB-12
	3	AC NEUTRAL	PB-10
	4	LOGIC GROUND	----

EXPANSION OUTPUTS
C/C 33284G8

J16	FUNCTION	TO
17	DET. 17 / PMT. A OUT	MP: B19
18	DET. 18 / PMT. B OUT	MP: B20
19	PMT. C OUT	MP: B17
20	PMT. D OUT	MP: B18

DETECTOR LOOP INTERFACE

STACKED COMMUNICATION INTERFACE PANEL-4 MVP

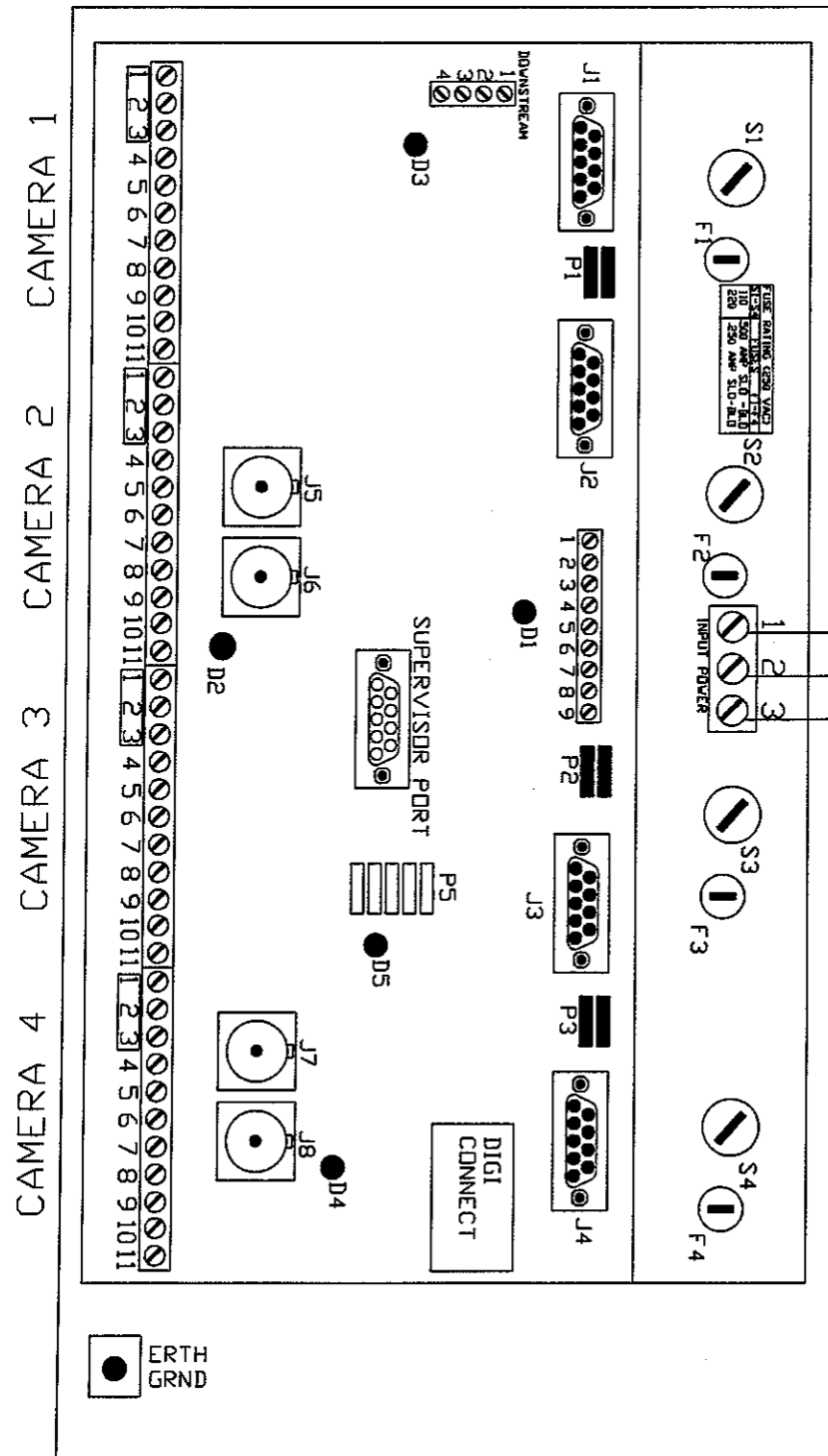

CAMERA 1	Ø1-6	SB
CAMERA 2	Ø2-5	NB
CAMERA 3	Ø3-8	WB
CAMERA 4	Ø4-7	EB

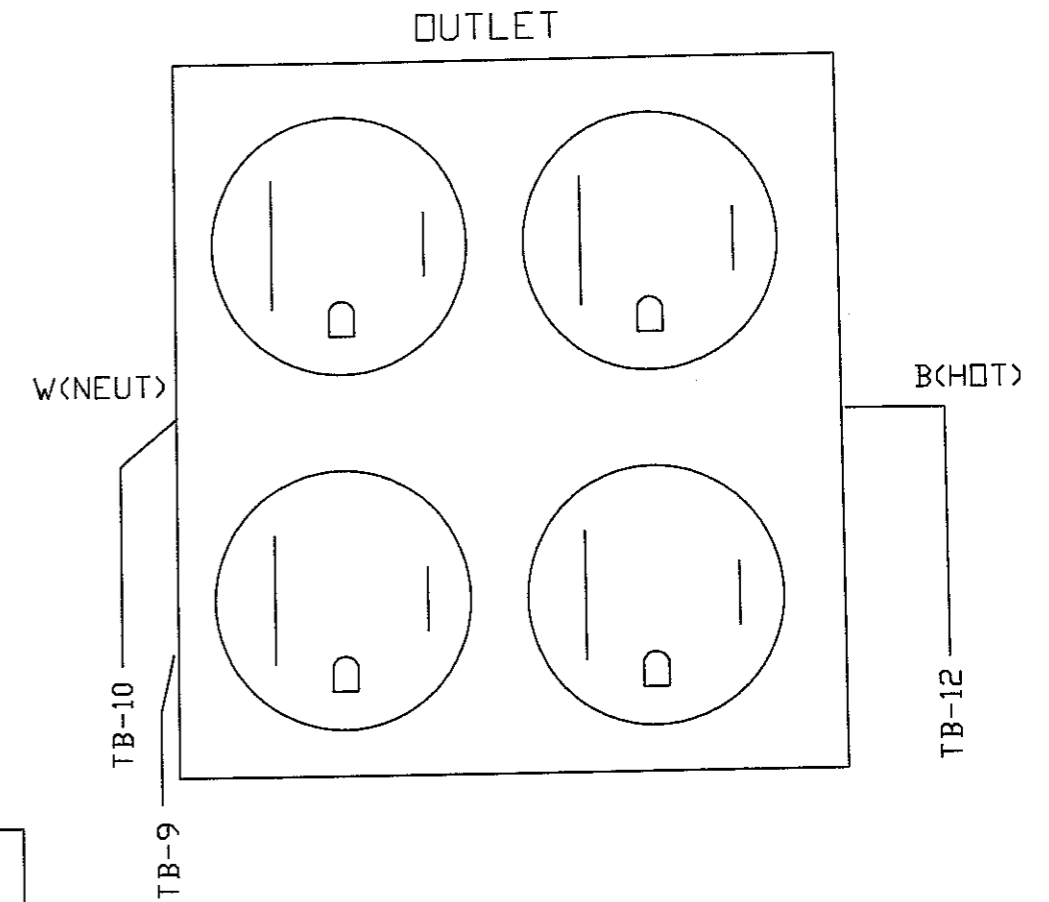
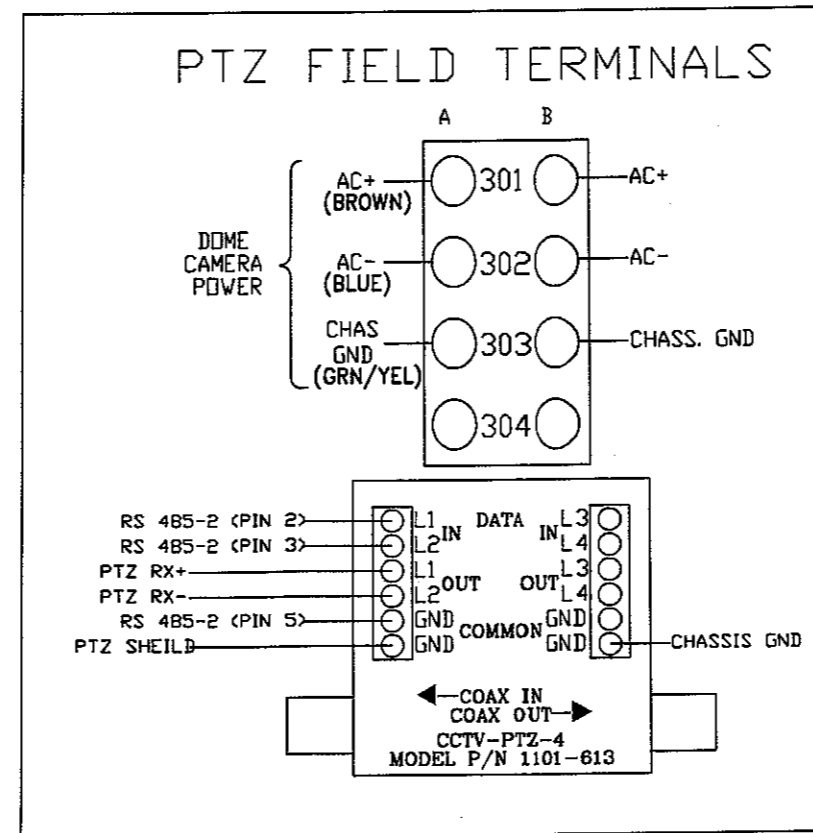

SOLO CAMERA FIELD HOOKUP

MVP CABLE#		BRANCH COMMUNICATIONS CABLE (CABLE FROM POLE TO CABINET) (WRITE IN COLOR)		HUB INTERFACE PANEL	DRI INTERFACE PANEL
PIN	PAIR COLOR	WIRE COLOR	PAIR COLOR	SIGNAL	TERMINAL
A	BRN/BLK	BRN		24V PWR 1	1
B	BRN/BLK	BLK		24V RTN 1	2
N	---	GRN/YEL		EARTH GND 1	3
P	BLU/BLK	BLU		SUP RX+	4
U	BLU/BLK	BLK		SUP RX-	5
D	RED/BLK	RED		SUP TX+	6
R	RED/BLK	BLK		SUP TX-	7
F	YEL/BLK	YEL		DET+	8
E	YEL/BLK	BLK		DET-	9
J	WHI/BLK	WHI		VIDEO+	10
H	WHI/BLK	BLK		VIDEO-	11
	DRAIN	BARE	DRAIN BARE		*SEE NOTE

*BARE DRAIN WIRES TO BE TERMINATED AT EARTH GRND TERM ON INTERFACE PANEL

REMOVE JP1 AND JP2 WHEN USING EXTERNAL POWER SUPPLY FOR THE ASC3 CONTROLLER

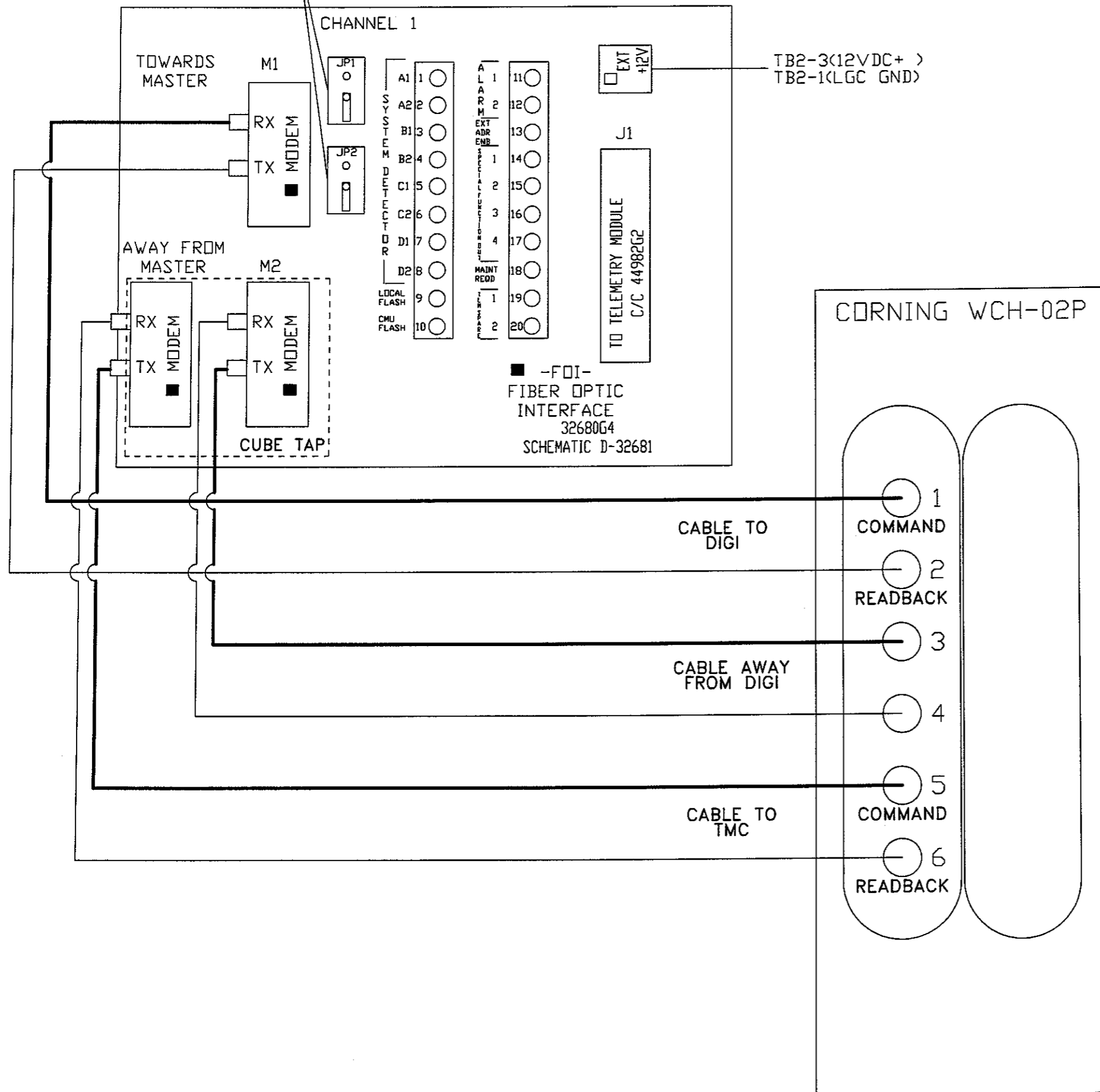

		-LT- LOCAL TELEMETRY 32680G4	
CONT. TELM. PORT	FIBER OPTIC INTERF.	COLOR	FUNCTION
J3	J1		
3	A4	BLACK	TRANSMIT
2	A3	BLACK	RECEIVE
7	A5	RED	+12 VDC
5	A2	GRAY	SIG. GND.

LOCAL RS-232 TELEMETRY (FOI)

AC CONNECTOR

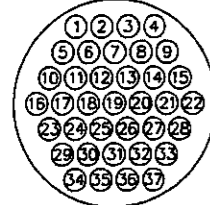

UPS TO BYPASS CABLE
UPS CONNECTOR BYPASS CONNECTOR

PIN	COLOR	FUNCTION	PIN
16	RED	UPS OUTPUT	1
22	BLACK	UPS INPUT	2
		NOT CONNECTED	3
18	WHITE	NEUTRAL	4
20	WHITE	NEUTRAL	5
7	GREEN	CHASSIS GND	6

BEACON
AC+ AC-
105A

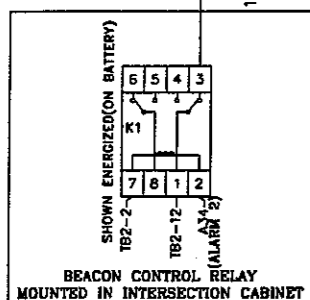

RLY OUT CABLE

PIN	COLOR	FUNCTION	TO
1	YELLOW	AC-OFF COM	A29
2		AC-OFF NC	N/C
3	BROWN	AC-OFF NO	A23
4	WHITE	ON BATT COM	A35
5		ON BATT NC	N/C
6	BLACK	ON BATT NO	A34
7	GREEN	FLASH COM	A35
8	RED	FLASH NO	A37
9		FLASH NC	N/C
10	PURPLE	FAIL/OFF COM	A29
11		FAIL/OFF NC	N/C
12	ORANGE	FAIL/OFF NO	A24
13	RED	EPO CONTACT 1	K3-1
14	BLACK	EPO CONTACT 2	K3-4

RELAYS

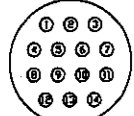

SEPERATE CABLE

FRONT VIEW

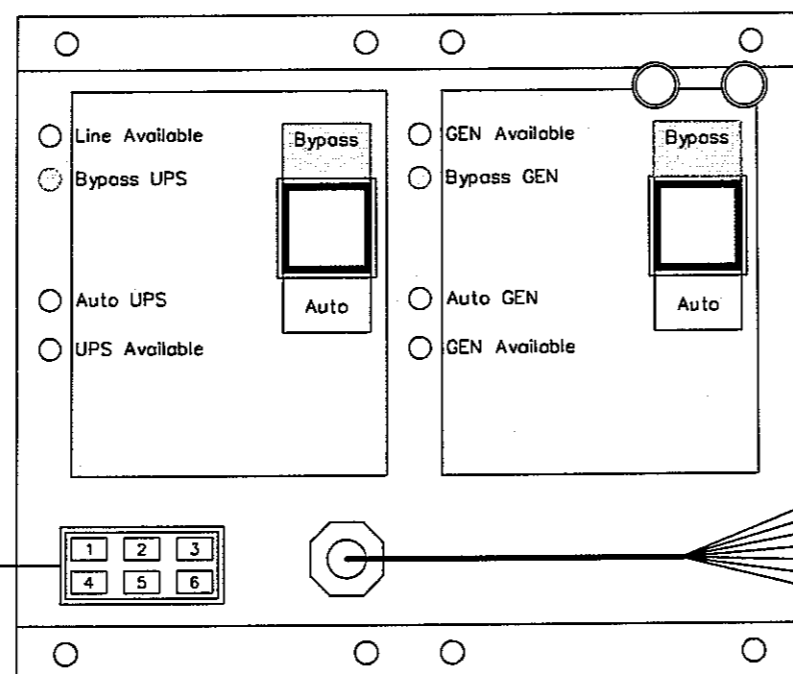

LINE/LOAD CABLE

COLOR	FUNCTION	TERMINAL
BLACK	AC INPUT	CB1-2
WHITE	AC INPUT NEUTRAL	105A
RED	AC OUTPUT TO LOAD	101A
WHITE	AC OUTPUT NEUTRAL	102A
GREEN	GROUND	103A
ORANGE	GENERATOR LINE	
WHITE	GENERATOR NEUTRAL	

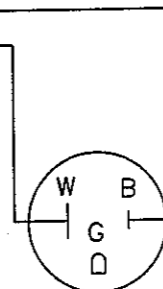

TWIST LOCK GENERATOR PLUG
MOUNTED IN POLICE PANEL

EMERGENCY POWER OFF CIRCUIT

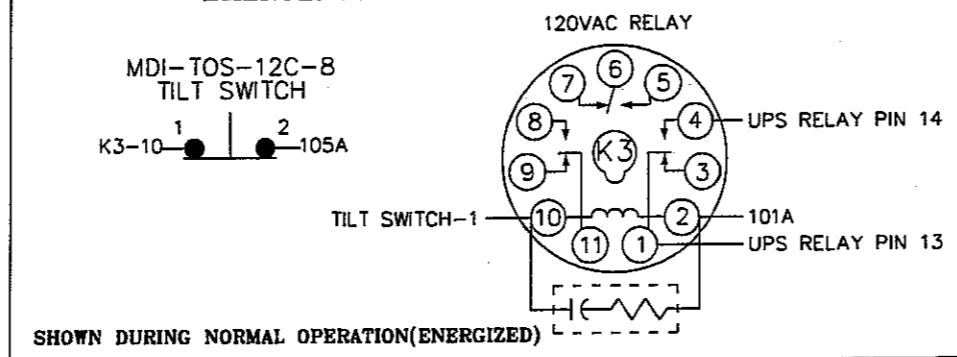

SHOWN DURING NORMAL OPERATION(ENERGIZED)

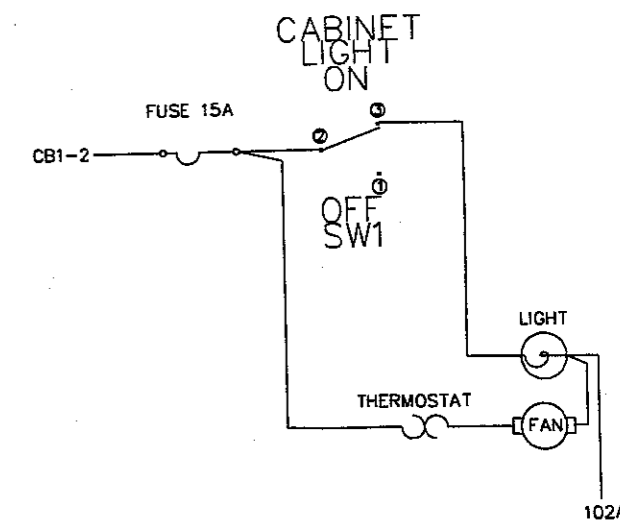

CHAS. GND

BATTERIES

FOUR BATTERIES IN SERIES/PARALLEL TO MAKE A 24V SYSTEM

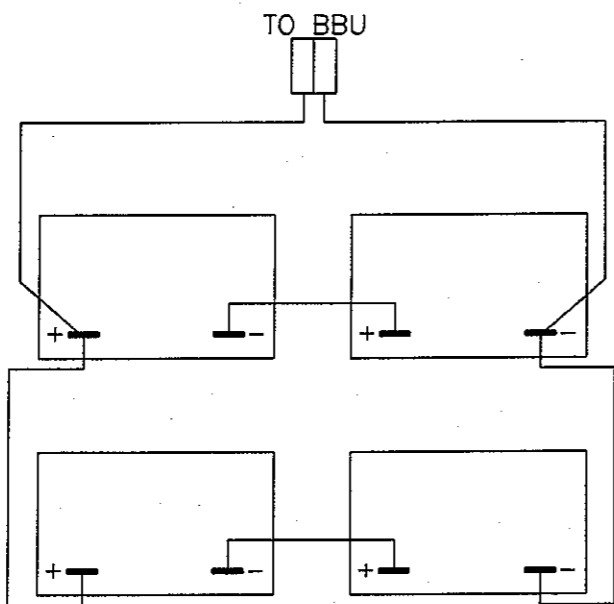

PROTECT EYES AND HANDS WHEN CONNECTING BATTERIES

B.B.U. INTERFACE
INSIDE INTERSECTION CABINET

